



Second Term Test - Grade 13 - 2020

Index No.

Physics I

2 hours

- ❖ This paper consists of 50 questions and Answer all the questions.
- ❖ Use of calculator is not allowed.
- ❖ Write your index number in the space provided in the answer sheet.
- ❖ In each of the questions 1 to 50 pick one of the alternatives from (1),(2),(3),(4),(5) which is correct or most appropriate and mark your response on the answer sheet with a cross (x) in the answer sheet.

01. The symbol of unit for solid angle in SI unit system is,
 (1) rad (2) srad (3) strad (4) sr (5) str
02. The dimension of coefficient of surface tension is,
 (1) LT^{-2} (2) L^2T^{-2} (3) MLT^{-2} (4) MLT^{-1} (5) MT^{-2}
03. (a) If the total momentum of system is constant, the total energy of system is constant.
 (b) If the kinetic energy of the object is constant, the momentum of it is constant.
 (c) The acceleration of a uniform speed object is always zero.
 From above statement,
 (1) Only (a) is true (2) Only (C) is true (3) Only (a) and (b) are true
 (4) Only (b) and (c) are true (5) All statements are false.
04. When the external jaws of vernier caliper contact to each other, the zeros of the two scales are not collinear but 4th mark of the vernier scale is colinear with the 4th mark of the main scale. When the measurements are taken from this vernier caliper.
 (1) 0.4 mm should be added to the measurement.
 (2) 0.4 mm should be subtracted from the measurement.
 (3) 4 mm should be added to the measurement.
 (4) 4 mm should be subtracted from the measurement
 (5) No need to change the measurement.
05. The error of the stop watch that use in the experiment to find the acceleration due to gravity by using simple pendulum is 0.1s If the period is 1.2s , when the time are taken to 25 oscillations, the percentage error is,
 (1) 33% (2) 3.3% (3) 0.33% (4) 0.0033% (5) 0.033%

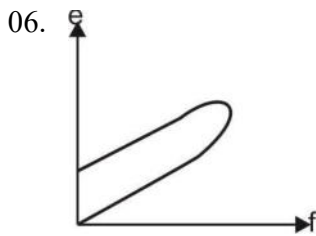

The force F is applied on elastic string upto exceed elastic limit and then gradually decreases up to zero. The variation of extended distance (e) and force is shown in the graph. The energy that can be regain in the graph. The energy that can be regain from the extended string is best shaded by,

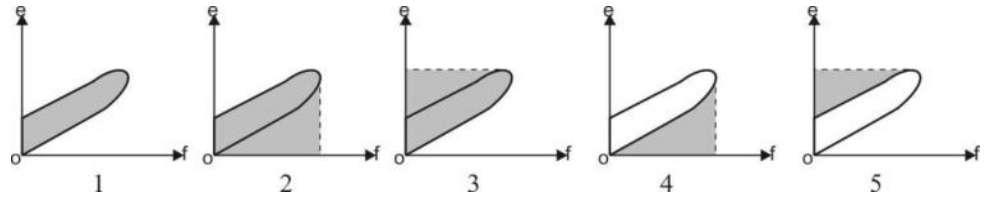

07. The bullet of mass $8g$ is fired with the speed of 126 ms^{-1} to the stationary wooden block of mass 1 kg kept on the horizontal smooth plane. after collision if the bullet comes to rest in the wooden block, the initial speed of the system is"

- (1) 0.5 ms^{-1} (2) 1 ms^{-1} (3) 1.008 ms^{-1} (4) 2 ms^{-1} (5) 2.004 ms^{-1}

08. There are four displacement time graphs below. In which graphs / graphs represent the opposition between velocity vector and acceleration vector.



- (1) a and b (2) c and d (3) a and c (4) b and c (5) b and d

09. The rate of rotation of an object is increased up to 600 rpm after completing the 20 revolutions from rest under angular acceleration due to constant torque. If the moment of inertia of the object about the axis is 6 kgm^2 , The impulse act on the object is, ^ take $\pi = 3$ &

- (1) 60 Nm (2) 75 Nm (3) 90 Nm (4) 105 Nm (5) 120 Nm

10. The cyclist, to move in a horizontal circular path of radius r with speed V change his cycle θ angle with horizontal,

- (1) $V^2 = \frac{\tan\theta}{rg}$ (2) $V^2 = \frac{rg}{\tan\theta}$ (3) $V^2 = \frac{rg}{\sin\theta}$ (4) $V^2 = \frac{\sin\theta}{rg}$ (5) $V^2 = \frac{\cos\theta}{rg}$



The coefficient of friction between floor and wedge of mass M is μ . The inclined surface is smooth, when B is released as shown in the figure, if the (A) is at rest, The frictional force act on. A is,

- (1) $\mu(M + m)g$ (2) μmg (3) $\mu(M + m\sin\theta)g$
 (4) $mg\cos\theta$ (5) $mg\sin\theta\cos\theta$

12. When the speed of sound in air is V , A sound source of "A" moves forward with speed $\frac{V}{4}$ emitting the sound of frequency f_0 . A motor care B moves to opposite direction on the same path with speed $\frac{V}{5}$, the hearing sound frequency of the observer at motor car B is,

- (1) f_0 (2) $16 f_0$ (3) $32 f_0$ (4) $16 f_0$ (5) $0.16 f_0$

13. If the hearing sound intensity level of a person at 5 m away from sound source is 20 dB the hearing sound intensity level at 10 m distance is"

- (1) 14 dB (2) 26 dB (3) 40 dB (4) 30 dB (5) 10 dB

14. When the pendulum resonance under certain frequency,
 (A) The natural frequency of the pendulum is equal to the certain frequency.
 (B) Oscillate with maximum frequency
 (C) Energy transmission to the pendulum is maximum.

Correct statement is,

- (1) Only A (2) Only B (3) Only C (4) Only A and B (5) Only A,B and C

15. According to the gravitational Law of Newton's, the mutual force act on two objects is,
 (a) It may be attractive or repulsive
 (b) It is directly proportional to the each mass
 (c) Inversely proportional to seperation between two masses

Wrong statement is/ are,

- (1) Only a and c (2) Only b (3) Only a (4) Only c (5) only b and c

16. Consider the following statement about the motion of a satellite around the earth. The wrong statement is,

- (1) The centripetal force for the motion of satellite provide by the gravitational force between earth and satellite.
 (2) The rotational period of geostationary satellite is equal to the rotational period of the earth
 (3) The angular velocity of geostationary satellite is equal to the angular velocity of the earth.
 (4) The total energy stored in the satellite is depend on the potential at a point in the moving orbit.
 (5) To leave the satellite form earth gravitational field, the minimum velocity that should be given to the satellite from earth surface is escape velocity.

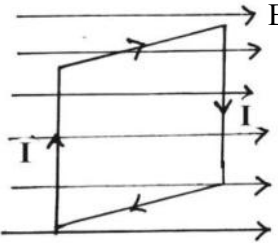
17.  The coil of "n" number of turns is kept inclined to the horizontally magnetic field of flux density B . The inclination of the coil to the field is α , the current flow through the each turn in the coil is I , when the plane of the coil is parallel and perpendicular , the torque act on the coil is respectively,
 (1) Minimum, maximum (2) Maximum, maximum
 (3) Maximum, minimum (4) Minimum, Minimum
 (5) No changes

18. The object of mass m is projected vertically upwards with velocity V When the object return to the initial position,
 (a) The initial velocity is equal to the final velocity.
 (b) The impulse act on the object is zero.
 (c) The effective work done on the object by gravitational force is zero.

of the above statements,

- (1) Only (a) is true (2) Only (b) is true (3) Only (c) is true
 (4) Only (a) and (c) are true (5) Only (b) and (c) true

19. An object of mass M and volume V is at equilibrium on the base of container filled with liquid of density ρ , when the container move upwards with acceleration g , . The reaction act on the object by the base of the container is,

- (1) Zero (2) mg (3) $(2m - v\rho)g$
 (4) $2(m - v\rho)g$ (5) $(m - v\rho)g$

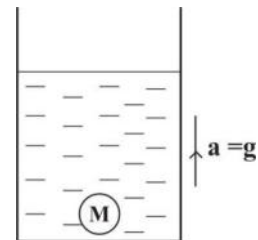

20. The total energy of satellite of mass M that moves with constant velocity V orbit of radius r around the sun of mass m is E_1 , It the total energy of another satellite of mass $m/2$ and moving with constant velocity V in a circular orbit of radius $2r$ is E_2 the value of $E_1 : E_2$ is,
 (1) $1 : 4$ (2) $4 : 1$ (3) $8 : 1$ (4) $1 : 8$ (5) $1 : 1$

21. The electrostatic force of 0.07 N is act on the charge of $2.8 \times 10^{-5}\text{ C}$ that kept on a point in electrostatic field, The electric field intensity at that point is,
 (1) $2.5 \times 10^{-2}\text{ Nc}^{-1}$ (2) $4 \times 10^4\text{ Nc}^{-1}$ (3) $4 \times 10^2\text{ Nc}^{-1}$
 (4) $25 \times 10^2\text{ Nc}^{-1}$ (5) $25 \times 10^4\text{ Nc}^{-1}$

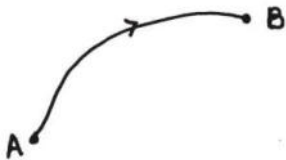
22.  The potential at a point A and B in the uniform electric field are $V_A = 2.8\ \mu\text{V}$ and $V_B = 4.6\ \mu\text{V}$ respectively. The work done need to move q charge from point A to point B is"
 (1) $1.8 \times 10^{-6}\text{ J}$ (2) 1.8 qJ (3) $1.8 \times 10^{-3}\text{ qJ}$ (4) $1.8 \times 10^{-6}\text{ qJ}$ (5) 1.8 J

23. The current flow outwards through the long conductor that kept perpendicular to the plane of the paper, the magnetic field around the conductor is best represented by,

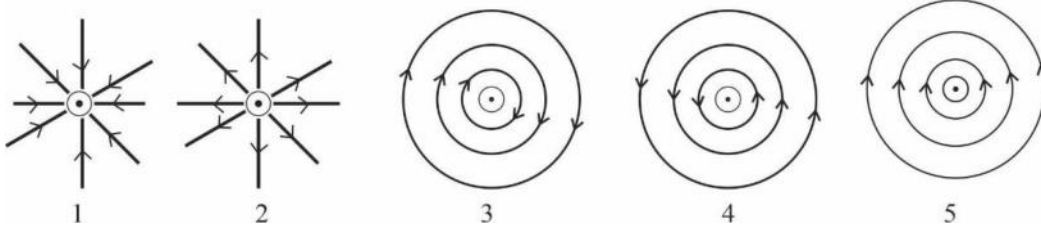

24. In the object cools under convection the temperature decreases 80°C to 70°C within 3 min and 80°C to 60°C within 7 min. The time taken to decrease the temperature 50°C to 40°C is,
 (1) 2 min (2) 3 min (3) 4 min (4) 5 min (5) 8 min

25. The magnetic field intensity at the centre of the solenoid is B when the radius and current of the solenoid are doubled and the number of turns are halved, the magnitude of the new field is,"
 (1) $2B$ (2) $4B$ (3) $\frac{B}{2}$ (4) B (5) $\frac{B}{4}$

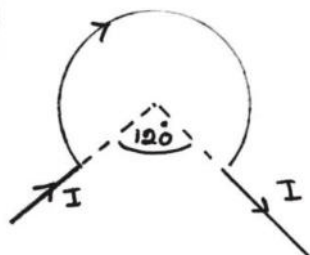
26.  Two infinite long wires are connected to the wire that bend as a circular arc of radius R as shown in the figure. when the current I passing through the wire, the magnetic flux density at centre is,
 (1) $\frac{\mu I}{6R}$ (2) $\frac{\mu I}{3R}$ (3) $\frac{\mu I}{R} \left(\frac{1}{3} + \frac{1}{2\pi} \right)$
 (4) $\frac{\mu I}{2R} \left(\frac{1}{3} + \frac{1}{\pi} \right)$ (5) $\frac{\mu I}{R} \left(\frac{1}{3} + \frac{1}{\pi} \right)$

27. Consider the following statements regarding Hall Effect.
 (A) Hall voltage is formed when the direction of magnetic field is not parallel to the direction of current.
 (B) The direction of hall voltage is prepared perpendicular to the perpendicular component of magnetic field and the electric current.
 (C) Hall effect is a resultant of a buildup force due to charge moving in a magnetic field.
 of the above statements,
 (1) Only (A) is true (2) Only (B) is true (3) Only (A) and (C) are true

- (4) Only (B) and (C) are true (5) All (A),(B) and (C) are true

28. The back E.M. F of battery is E , when the current of $3.0A$ draw by the direct current motor of internal resistant 1.5Ω . Potential difference across battery is $60V$. When the motor is worked complete load by drawing the current, the value of E and power given by the motor P are,
 (1) $E = 60V$ and $P = 13.5 W$ (2) $E = 55.5V$ and $P = 13.5 W$
 (3) $E = 64.5V$ and $P = 6.75 W$ (4) $E = 64.5V$ and $P = 13.5 W$
 (5) $E = 50.5V$ and $P = 6.75 W$

29. The marked current in a fuse is $10A$. The length and area of cross section $6 cm$ and $4mm^2$ respectively. The temperature coefficient of wire at $30^{\circ}C$ is $1.8 \times 10^{-8} \Omega m$. The resistance of the wire at $30^{\circ}C$ is,
 (1) $2.7 \times 10^{-4} \Omega$ (2) $5.4 \times 10^{-4} \Omega$ (3) $2.7 \times 10^{-2} \Omega$
 (4) $5.4 \times 10^{-2} \Omega$ (5) 0Ω

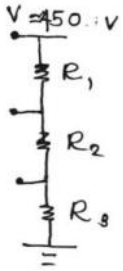
30.  When the potential difference of $450V$ is applied to the potential divider shown in the figure. The current passing through the system is $1mA$. The potential across the R_2 is twice that of R_1 , the potential across R_3 is three times that of R_2 . The values of R_1, R_2 and R_3 respectively,
 (1) $50\Omega, 100\Omega, 300\Omega$ (2) $5\Omega, 10\Omega, 30\Omega$ (3) $50k\Omega, 100k\Omega, 300k\Omega$
 (4) $300k\Omega, 100k\Omega, 50k\Omega$ (5) $300\Omega, 100\Omega, 50\Omega$

31. The object that moves in constant velocity becomes stationary when the constant resultant force applied on it. The variation of kinetic energy with displacement is best represented by,

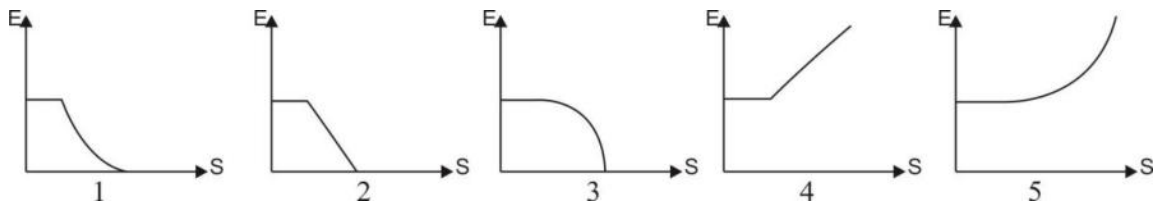

32. The effective area of the wings in areoplane is A The speeds of air above the wing and below the wing are V_1 and V_2 respectively. When the density of the air is ρ , the perpendicular thrust act on the areoplane is,

(1) $\frac{\rho A (V_2^2 - V_1^2)}{2}$ (2) $\frac{\rho A (V_1^2 - V_2^2)}{2}$ (3) $\frac{\rho A V_1^2}{2}$ (4) $\frac{\rho A V_2^2}{2}$ (5) $\frac{\rho A (V_1 - V_2)}{2}$

33. When the temperature of the fixed mass of the air at constant pressure is increased form $0^{\circ}C$ to $101^{\circ}C$ the change at volume is V . The volume of the gas at $0^{\circ}C$ is,

(1) $273 V$ (2) $\frac{V}{273}$ (3) $\frac{V}{100}$ (4) $\frac{V}{101}$ (5) $100V$

34. The following figure shows the $P - V$ curves of ideal gas, the graph suitable to the isothermal process is,

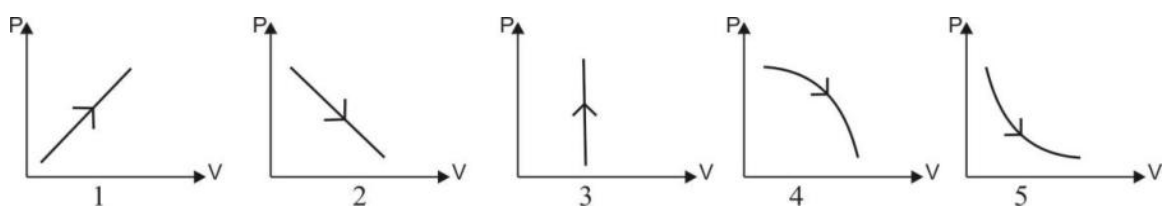

35. The heater of $700 W$ is used to boil the $1kg$ of water at $20^{\circ}C$ in the container of heat capacity

$700 J^{\circ}C^{-1}$. The minimum time taken to start to boil the water is \hat{s} .h.c. of water $4200 jkg^{-1}^{\circ}C^{-1}$ &
 (1) 6 min (2) 8 min (3) 9.33 min (4) 480 min (5) 560 min

36. The wrong statement from following,

- (1) Potential is a scalar quantity.
- (2) The potential on the equipotential surfaces is zero.
- (3) The potential at any point on the equipotential surface is constant.
- (4) Electric field intensity is equal to the negative value of potential gradient.
- (5) There is no energy exchange, when the charge is moving on the equipotential surface.

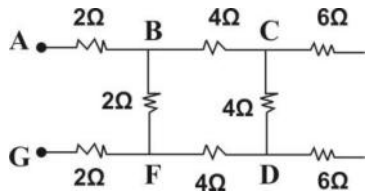
37.  If the potential difference between the point A and G in the given circuit is 20V , the current passing through the 2Ω resistor,
 (1) 0 (Zero) (2) 14 A (3) 1.75 A
 (4) 7 A (5) 3.5 A

38. The length and area of cross section of elastic string are 1 m and $2 \times 10^{-6} mm^2$ respectively when the force of 100 N act on the string, the extension of the wire is 1 mm . The energy stored in the unit volume of the string is,

- 1) 25 KJ (2) 2.5 KJ (3) 0.25 KJ (4) 250 KJ (5) 25×10^3 KJ

39. The same forces are act on the strings X and Y without exceeding the elastic limit. The length of the X is twice that of Y and radius of X is halved that of Y . If the both string are make by same material the ,

$\frac{\text{Extension of X}}{\text{Extension of Y}}$ is,

- 1) $\frac{1}{2}$ (2) 1 (3) 2 (4) 4 (5) 8

40. Intrinsic semi conductor can be convert as extrinsic semi conductor,

- (a) by adding doner atomy
- (b) by adding accetor atoms
- (c) by increasing the temperature

of the above statement,

- (1) Only (a) is true (2) Only (b) is true (3) Only (a) and (b) are true
 (4) All (a), (b) and (c) true (5) Only (a) and (c) are true

41. If the volume of B = 1 in the given logic gate,

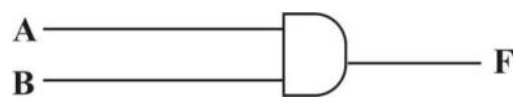

- (1) Only when A = 1, f = 1 (2) Only when A = 1, f = 0
 (3) Only when A = 0, f = 1 (4) Only when A = 0, f = 0
 (5) Only when A = 0, A = 1, f = 1

42. The factor that affected to the accuracy of the mercury – glass thermometer is,

- (1) Area of the cross – section of the capillary tube
- (2) The density of the mercury
- (3) The coefficient of volume expansion of glass.
- (4) The specific heat capacity of the mercury

(5) The thermal conductivity of the glass

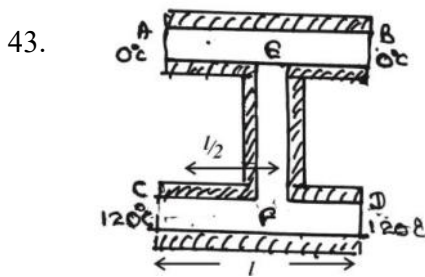

Well lagged three rods of identical dimensions and same material are connected as shown in the diagram. The end A,B,C and D are maintained at the temperatures given in the diagram when the system is steady. The temperature difference between E and F is.

- (1) $20^{\circ}C$ (2) $40^{\circ}C$ (3) $60^{\circ}C$
 (4) $80^{\circ}C$ (5) $100^{\circ}C$

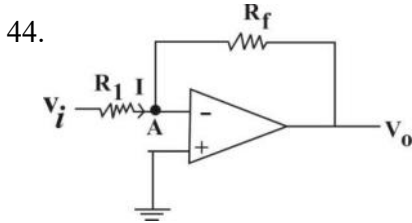

Following figure shows the operational amplifier circuit, If the $R_f = 175 K\Omega$ and $R_1 = 25 K\Omega$ the ratio of $\frac{V_o}{V_i}$ is,

- (1) +7 (2) -7 (3) 70
 (4) $+\frac{1}{7}$ (5) $-\frac{1}{7}$

45. The period of the pendulum bob in the clock that is connected to the lift is T_0 when the lift is moving downward with acceleration $5 ms^{-2}$. The new period of the pendulum bob is,

- (1) $2 T_0$ (2) $T_0/3$ (3) $\frac{T_0}{\sqrt{2}}$ (4) $\sqrt{2} T_0$ (5) $\sqrt{2} \cdot T_0$

46. The fundamental frequency of the string is f_0 . The frequency of the string becomes $f_0/2$, when,

- (1) The tension of the string is halved (2) The length of the string is doubled.
 (3) The tension of the string is doubled (4) The diameter of the string is doubled
 (5) The length of the string is halved.

47. The velocity of sound in air at the environmental temperature $27^{\circ}C$ is $330 ms^{-1}$. The velocity of sound in air in a day of environment $30^{\circ}C$

- (1) $330\sqrt{10.1} ms^{-1}$ (2) $330\sqrt{1.01} ms^{-1}$ (3) $330\sqrt{101} ms^{-1}$ (4) $\frac{330}{\sqrt{1.01}} ms^{-1}$ (5) $\frac{330}{\sqrt{10.1}} ms^{-1}$

48. When the air blow to the both end open tube by closing the one end of the tube using a finger. It emits the sound of frequency of $256 Hz$ when the finger is removed, the new frequency of sound is,

- (1) $256 Hz$ (2) $512 Hz$ (3) $128 Hz$ (4) $300 Hz$ (5) $384 Hz$

49. Following graphs shows the variation of the potential at a point in an electric field with distance from reference point. The graph best represent the uniform electric field is,

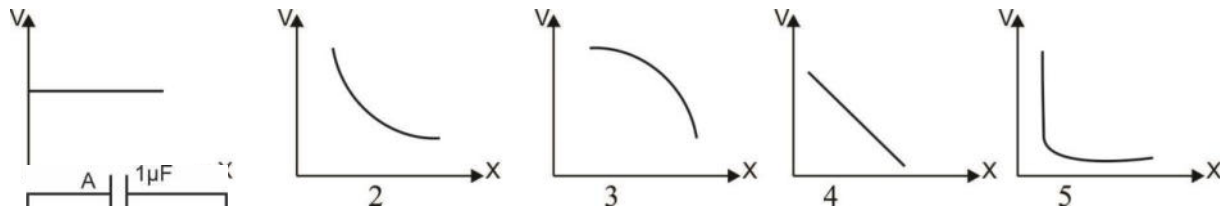

50. Three capacitors are charged by connecting the battery of 12V as shown in the figure. If the stored charge in each capacitor is Q_A, Q_B, Q_C respectively

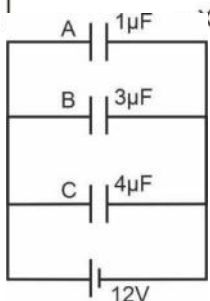

- (1) $Q_A = Q_B = Q_C$ (2) $Q_A < Q_B < Q_C$ (3) $Q_A > Q_B > Q_C$
 (4) $Q_A > Q_B < Q_C$ (5) $Q_A = Q_B < Q_C$



Provincial Department of Education - NWP

01 E II

Second Term Test - Grade 13 - 2020

Index No.

Physics II

3 hours

- ❖ This paper consists of two parts A and B allowed time for both parts is 3 (three) hours.
- ❖ Answer all the questions of **part A** on this paper itself. You must use the given space to answer. No lengthy answers are expected.
- ❖ **Part B** consists of 6 questions. Answer only four of them. After the exam, attach part A and part B and hand over to the staff.
- ❖ Use of calculators is not allowed.

Part - A (Structured Essay)

01. A student followed following steps during an experiment of finding relative density of a metal..
1. A sphere made up of that metal was suspended from spring balance and the balance reading was taken (w_1)
 2. The sphere was completely immersed in water and then the balance reading (apparent weight , w_2) was taken.
The readings are in newton.
- i) If the volume of the sphere is V and density of the metal is d , write an expression for W_1 .
.....
.....
.....
 - ii) Write an expression for the upthrust on the sphere in the step 2 in terms of density of water.
.....
.....
.....
 - iii) Derive an expression for relative density of the metal using (w_1) and (w_2)
.....
.....
.....
 - iv) State one important point that has to be considered during step 2.
.....
.....
.....

v) If several spheres made up of that material are given, the sphere having highest mass which can be measured with the given balance should be used for the experiment. Give two reasons for that.

.....
.....
.....
.....

vi) The volume of the sphere is 200cm^3 and density of water is 1000kgm^{-3} . The values obtained for w_1 and w_2 were 8.01N and 5.99N respectively.

a) Find the upthrust on the sphere when it is fully immersed in water .Use Archimedes principal for that

.....
.....
.....

b) Is there a difference between the values (W_1-W_2) and the value obtained for (a)? If there is a difference, state the reasons for that.

.....
.....
.....
.....

c) Find the density of the metal relative to water using values of W_1 and W_2

.....
.....
.....

02. A student arranged an experiment to determine specific latent heat of fusion of ice by the method of mixture. He collected a calorimeter with water, crushed ice, small cubes of ice and large ice cubes.

a) What are the required measuring instruments for this experiment?

.....
.....

b) The student supposed to start the experiment with water in the calorimeter that is few degrees above the room temperature and to finish it with the same number of degrees below the room temperature. What is expected by this process?

.....
.....
.....

c) i. Which form of ice should be used by him?

.....

ii. Give scientific reasons for the rejection of other two forms

.....
.....
.....

d) What is the essential process that is required to follow while adding ice to the calorimeter?

.....
.....
.....

e) If he conducts the experiment without above process, how it affects on the final result

.....
.....

f) The student obtains following data and readings from the experiment.

Heat capacity of calorimeter and stirrer = 42 JK^{-1}

The initial mass of water in the calorimeter = 100 g

Initial temperature of water = 37°C

Final temperature of water = 27°C

Mass of the dissolved ice = 10 g

Specific heat capacity of water = $4.2 \times 10^3 \text{ Jkg}^{-1} \text{ K}^{-1}$

Calculate experimental value of specific latent heat of fusion of ice

.....
.....
.....
.....
.....
.....

g) The student repeated the experiment in another day under the same room temperature using same instruments and same amount of water. But while taking the final temperature, he observed the formation of dew on the surface of calorimeter. How this experimental value of specific latent heat of fusion of ice is differ from the value calculated from the previous experiment?

.....
.....
.....

03. A student uses a large lens to observe magnified image of a point object.(the least distance of distinct vision(D) is 25 cm)

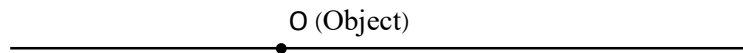

He expected to keep his eye on the right side of the object.

- i) Place the lens at the suitable place and mark the position of the eye relative to that.
- ii) Mark the focal point F relative to the object.

iii) Draw a path of a light ray from object to the eye.

iv) Is the image real or virtual?

v) Write an expression for the magnification of image using D and f.

.....
.....
.....
.....

vi) If the focal length of the lens is 5 cm, calculate the magnification of the image.

.....
.....
.....

vii) Since the magnification is not enough, a compound microscope is made by using another magnifying lens of focal length 12.5 cm. He expects to observe the final image for a long time with this. Mark eyepiece, object piece and the position of the eye correctly.

viii) Mark the focal points of the eyepiece and the object piece and the position of the object

ix) If the magnification of the eyepiece is 5, what is the total angular magnification of the compound microscope in normal adjustment?

.....
.....
.....

x) Draw the path of a light ray coming from object to the eye.

04. An electrical component P has an internal resistance R_0 . An ammeter A and a voltmeter V have been connected to the circuit as shown to measure the current and the voltage across P

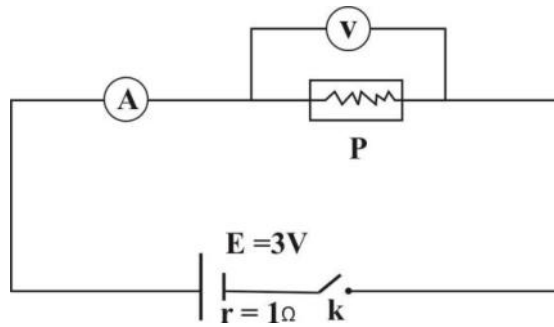

i) If the reading of V is V_p and A and V are ideal instruments, write an expression for the ammeter reading in terms of E , V_p and r .

.....

ii) If the reading of A is $1A$ find the voltage across P .

.....

iii) The voltage across P is measured by a voltmeter which has an internal resistance. If the internal resistance of V is,

a) equal to the resistance of P

b) equal to half of the resistance of P

c) equal to one fourth of the resistance of P

d) twice the resistance of P

Write expressions for the readings of A (I_A) in terms of E, R_0 and r . Assume the ammeter A is an ideal one.

.....

.....

iv) If internal resistance of P is 1Ω for above instances, find the ammeter readings.

a)

b)

c)

d)

v) If the voltmeter reading (across P) is measured as in part (iii), is it different or equal to the actual voltage difference across P ? Explain your answer

.....

.....

.....

vi) He decided to connect the ammeter as shown below to measure the current through the component P

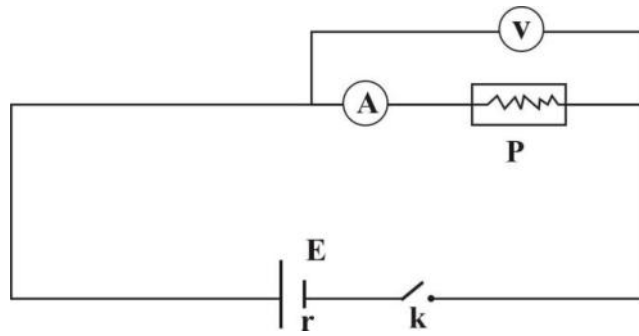

If the internal resistances of V and A are R_V and R_A respectively and the reading of ammeter is I_A , write an expression for the voltmeter reading in terms of I_A , R_A and R_P .

.....

.....

.....

.....

SecondTerm Test - 2020
Physics Part II - Grade 13
Part B (Essay)

• **Answer only four questions.**

05. When a car is travelling along a horizontal road, the forces of resistance against the motion are,

1. The force of friction on the tyres (rolling resistance)- F_r
2. Aerodynamic drag - F_D

In addition, when a vehicle is moving up along an inclined road, the resolved component of the weight of the vehicle that is parallel to the road can also be considered as a resistive force against the motion.

When a vehicle is traveling along an inclined road (inclination θ to the horizontal) with speed v , the above F_r and F_D values can be calculated by the following equations:

$$F_r = C_r mg \cos \theta$$

$$F_D = C_D V^2$$

C_r - Coefficient of Rolling resistance - depends on the nature of the road and tyres.

C_D - Coefficient of Air drag - depends on mean density of atmosphere and shape of the vehicle

a) The variation of F_D acting on a vehicle A, with its speed is given by the following graph

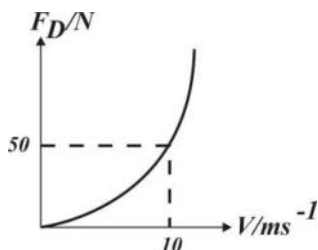

i). Calculate the C_D relevant to the vehicle

ii) When the speed of the vehicle is 20 m s^{-1} . what is the value of F_D

b) Consider an instant that the vehicle A traveling at a constant velocity of 30 m s^{-1} on a horizontal road. Then the engine output power of it is 28.5 kW . The mass of the car is 500 kg .

- i. Find the drive force of the engine at this instant.
- ii. Find the force F_r acting on the vehicle.
- iii. Calculate the C_r relevant to the vehicle.
- iv. If the maximum power output of the engine is 52 W and maximum speed on above road is V . Show that. $V^3 + 1000v - 104000 = 0$

c). If the maximum speed of a vehicle of mass 400 kg up along an inclined road (30° to the horizontal) is 30 m s^{-1} , find the maximum power output of its engine in kW . $C_r = 0.15$ & $C_D = 0.2$ (take the value $\cos 30^\circ = 0.8$)

d). Explain why it is important to take care of its shape when designing a car.

06. Read the paragraph given below and answer the questions

The disturbances propagating from one place to another is known as a wave. The waves that can only propagate through a material medium are known as mechanical waves. Media is essential for this wave propagation and cannot move through free space. The waves can be classified as transverse and longitudinal according to the relationship between the direction of propagation of the waves in a medium and the direction in which the particles are vibrating in the medium. The ripple tank and CRO can be used to observe the wave characteristics.

Sound waves propagate in the air as longitudinal waves. The speed of sound waves in air is directly proportional to the square root of the absolute temperature and does not depend on air pressure under constant temperature. The humidity of the atmosphere has little effect on the speed of sound wave speed in the air. But In general, the speed of the sound waves in the air is taken as 340 ms^{-1} . The stationary longitudinal waves formed in the tubes are often used in music. The stationary waves consisting stationary wave models and non-propagating energy, change according to the displacements of the particles in the existing medium. When the air is blown into the tube, the longitudinal stationary waves are formed in them. The progressive longitudinal wave formed in the tube due to the blowing air is reflected and superimposed, causing stationary waves in the tube. According to the speed at which air is inserted into the closed tubes and the open tubes, various complex stationary waveforms are formed

When an observer rests near a fixed acoustic source emitting a wave at a certain frequency, the observer hears the true frequency. But when the source or observer is in motion, the hearing frequency is different from the actual frequency. This result is known as the Doppler Effect.

The Doppler Effect for sound depends on three velocities. They are the velocity of source, the velocity of observer and the velocity of sound relative to the air. These velocities can be measured relative to the earth, since air is normally considered to be stationary relative to the earth.

The characteristic of a note is determined by the loudness, pitch and quality of it. The quality of the note allows us to distinguish a given type of musical instrument from the others. The loudness and the pitch can be linked to measurable physical quantities in an acoustic wave. The loudness depends on the sound intensity.

- a) What are the two types of waves classified according to the relationship between the direction of the waves in a medium and the direction in which the particles are moving?
- b) Define those wave types
- c) State three characteristics of stationary waves.
- d) How stationary waves are generated by blowing air into a tube?
- e) The speed of sound in a gas at 37°C and under the pressure $1.2 \times 10^5 \text{ Pa}$ is 350 ms^{-1} . Find the speed of sound in the gas at 87°C and under the pressure $1.7 \times 10^5 \text{ Pa}$.
- f) A child blows air into an open tube to vibrate it in fundamental mode. Draw existing stationary wave pattern in the tube and mark nodes and antinodes on it. Neglect end error. If the length of the tube is 40 cm , find the frequency of vibration of air in the tube
- g) As a boy blows that pipe and sits under a tree, another boy rushes toward him with a constant speed of 10 ms^{-1} and passes him. Calculate the frequency change of the sound that is heard by the running boy.
- h) Write two cases where the Doppler Effect results in practical use
- i) What factors influence the characteristics of sound?
- j) What is the intensity of sound heard by a person at a place of Sound intensity level 50 dB . The minimum sound intensity he can hear is $I_0 = 1 \times 10^{-12} \text{ Wm}^{-2}$

07. a) State Hooke's law and write an equation for the Young modulus of a metal that is used to make a wire. Introduce the terms in it.
 b) The following stress-strain curves are given for two wires made of two materials A and B

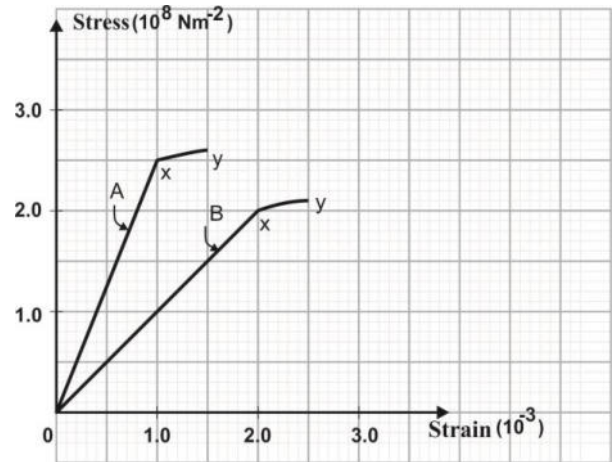

- i). What are the points X and Y on the graphs
 ii). Find the Young modulus Y_A and Y_B of the metals A and B
 iii). A composite wire has constructed using two similar metal wires made up of two materials A and B . They have connected,
 a). in series
 b) in parallel

The separately suspended loads from the composite wires are increased gradually. Which material will brake first in above compound wires? Explain the answer.

- iv). A composite wire is constructed by parallel connection of two wires made up of material A and B having equal lengths and cross sectional area 3 mm^2 . This composite wire is used to lift materials in a workplace.
 1). What is the maximum load that can be lifted so that no part of the composite wire is broken?
 2). What is the extension of the composite wire? The length of the composite wire is 5 m

08. a) State Gauss theorem.
 b) Derive an expression for electric field strength E at point P which is distance r away from a point charge $+Q$
 c) Define electric capacity
 d) Derive an expression for the capacity of a parallel plate capacitor in terms of A , d and ϵ .
 e) The plate area and plate separation of a capacitor are 5 m^2 and 5 mm respectively. If the space between the plates is a vacuum, calculate capacity of the capacitor ($\epsilon_0 = 8 \times 10^{-12} \text{ C}^2 \text{ m}^{-2} \text{ N}^{-1}$)
 f) Another capacitor similar to the above has included a dielectric material of relative permittivity 4 . Calculate its capacity.
 g) Now above two capacitors are charged separately by connecting to 2 kV .
 i.) Calculate charges stored in each capacitor separately.
 ii) Calculate total energy stored in the two capacitors.
 k) After charging the capacitors, they are connected by interchanging the terminals to construct compound capacitor.(+ terminal connected to $-$ terminal of the other)
 i) What is the charge stored in the compound capacitor
 ii) What is the new capacity of the compound capacitor
 iii) Calculate new amounts of charges stored in each capacitor separately.
 iv) What is the energy stored in the compound capacitor.

• **09 and 10 Questions, Answer part A or B only**

09. A) a) Is it possible to light a bulb labeled as $6V, 10W$ using only a cell of $6V$, with the relevant intensity? Explain qualitatively.

A circuit diagram containing cells and bulbs used by a child to decorate a Panola is given below

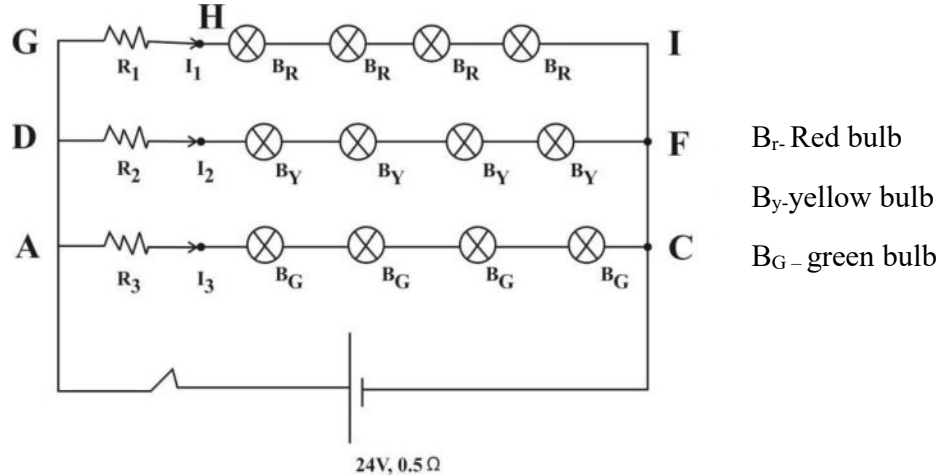

The red, yellow and green bulbs have rated as $(5W, 5V)$, $(4V, 4\Omega)$ and $(8W, 2A)$ respectively

- b) If the bulbs are lighting with relevant intensities,
- i). Find I_1 and I_2
 - ii). Find the potential differences between E and F and B and C .
 - iii). Determine the potential difference between the terminals of the cell
 - iv). Find R_1 and R_2
- c). If the green bulb in the circuit is burned,
- i) Find the current drawn by the lighting bulbs from the cell.
 - ii) If the rating current is increased by 5%, then all the bulbs will burn. At this instance is it possible to burn red or yellow bulb? Explain your answer.
- B) i) Sketch $I - V$ characteristic curve for a junction diode. How do you use these characteristics to distinguish Si and Ge diodes?
- ii). Draw a half wave rectification circuit and input and output waves of it.
- iii) A load resistor of 500Ω , a Si diode and ac voltage of peak voltage $30V$ are connected in series. If the resistance of the diode in forward bias is 50Ω , calculate peak current through the diode and peak output voltage.

The Following circuit shows a common emitter configuration of a npn transistor having dc current gain 250. An input voltage having peak value $2mV$ has applied through the capacitor C_1 to the base terminal. The ac voltage gain is 100

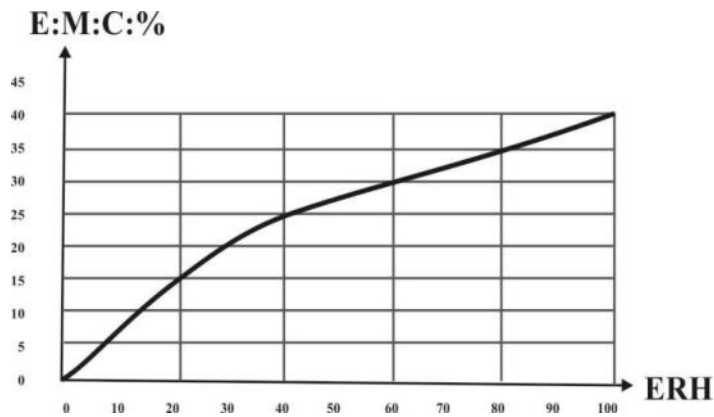

- iv) Calculate
- V_B
 - V_E
 - I_E
 - I_C
 - V_C
 - V_{CE}
 - Peak voltage of output signal (V_o)
- v) sketch the variation input and output voltages with time.

- 10 A) Silica gel, a moisture absorber, is used to control the relative humidity of a closed chamber

When a certain amount of dry silica gel is inserted into a closed chamber, the relative humidity of the chamber is reduced and becomes steady. Similarly, when the humidity is steady, the rate of absorbing moisture from air in the chamber by silica gel is equal to the rate of absorbing moisture by air in the chamber.

If the mass of moisture content of a silica gel sample is M_m and the mass of the silica gel sample when it is dry is M_s , the percentage of moisture content in the silica gel sample is defined as follows:

$$\text{Percentage of moisture content} = \frac{M_m}{M_s} \times 100\%$$

When the relative humidity of a closed chamber containing silica gel is steady, the percentage of moisture of the silica gel sample is called the equilibrium moisture content (EMC). The value at which the relative humidity becomes steady in the chamber containing silica gel at $30^\circ C$ is ERH . The graph shows how the value of EMC of the silica gel sample changes with ERH in a closed chamber containing silica gel.

- a). In order to test the performance of silica gel, a chamber of volume $1m^3$ at $30^\circ C$ consisting a relative humidity measuring device, is used. When a sample of dry silica gel is placed on an electronic balance in the chamber, the steady value of relative humidity of the chamber is 60% , and the then mass of the silica gel sample is $13g$.
- What is the EMC value of the silica gel sample?
 - Calculate the mass of dry silica gel sample inserted into the chamber

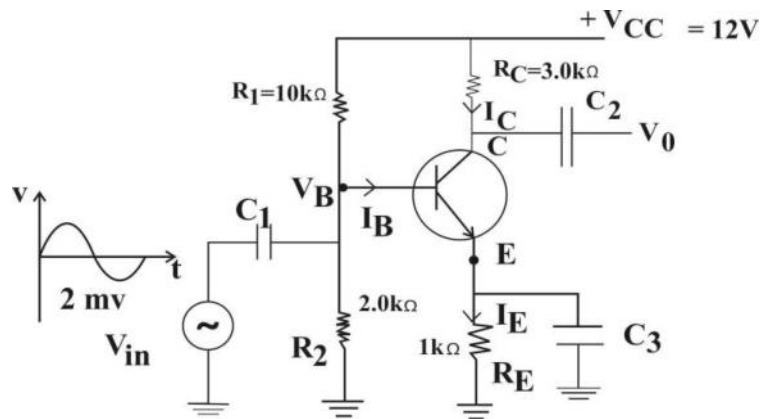

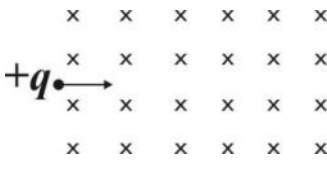
- b). The relative humidity in the closed chamber of volume 1m^3 at 30°C is reduced from 80% to 40% and kept steady by inserting dry silica gel in to the chamber.
- Calculate the absolute humidity in the chamber before putting silica gel. (Saturated vapor density at 30°C is 30 gm^{-3})
 - Calculate the mass of moisture absorbed by the silica gel when the humidity is steady.
 - Calculate the mass of the silica gel sample inserted into the chamber
- c). Before inserting the sample of silica gel in part (b), it has been stored for a long time in an environment where the relative humidity is 20% and the temperature is 30°C . Calculate the answer to b) (iii) again.
- d). In the case (b) above a wooden display is inserted into the chamber and again closed the chamber. Then the relative humidity in the chamber increases to 60% and becomes steady.
- Write a reason for the increment of relative humidity in the chamber
 - Explain how the increment of relative humidity in the chamber is controlled by silica gel.
- B) a) A positively charged particle with charge q , mass m is projected at a velocity V perpendicular to a uniform magnetic field of flux density B .
- Explain why the trajectory of the particle in the magnetic field is circular .
 - Derive an expression for radius r of the circular path
 - Find the radius of the path of a particle A of charge $1.2 \times 10^{-19}\text{C}$ and mass $1.8 \times 10^{-27}\text{kg}$, which enters perpendicular to a uniform magnetic field of magnetic flux density of 0.018 T with velocity $6.0 \times 10^5\text{ms}^{-1}$. Copy the given magnetic field in to the answer sheet and draw an outline of that path.
- 
- If a particle B that has twice the charge of the particle A and five times the mass of the particle A , enters the magnetic field at that velocity and at that point, find the radius of that particle B and outline of the trajectory in same diagram
 - If a neutral particle entered the magnetic field at the same speed and at the same place as the charge A mentioned in the above, then outline its trajectory on the same diagram.
- b). i). Write an expression for the magnitude of the magnetic field (B) at a point perpendicular distance d away from an infinitely long straight current carrying(I) conducting wire placed in a medium of permeability μ_0
- What is the direction of that magnetic field? What law should be used to obtain the direction?
 - An electric current of 5 A flows through an infinitely long straight conducting wire placed in the air ($\mu_0 = 4\pi \times 10^{-7}\text{ Nm}^{-1}\text{A}^{-1}$). Parallel to it, another very long conducting wire, with a spacing of 10 cm , was placed. In the second wire there is an electric current of 20 A flowing in the same direction as the electric current of the first wire. Find the position of the neutral point in the magnetic field caused by the electric current flowing through the two wires
 - Find the magnitude of the force exerted on the second wire by a length of 1 m of the first wire
 - If a charged particle of charge 10 C is placed at rest at the midpoint of the two wires, find the force acting on it.