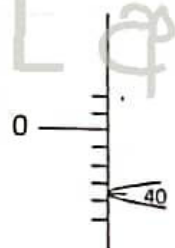

physics I

Time : 2 hours

$$g = 10 \text{ N kg}^{-1}$$

01. Dimension of Young's modulus is,
 (1). $M^1L^0T^{-1}$ (2). $M^1L^0T^{-2}$ (3). $M^1L^{-1}T^{-1}$
 (4). $M^1L^{-1}T^{-2}$ (5). Dimensionless
02. The percentage error of the measurement of $2g$ measured using a triple beam balance in the laboratory is,
 (1). 0.25% (2). 0.5% (3). 2.5%
 (4). 5% (5). 25%
03. The power of a convex lens is expressed as 2cm^{-1} . The power of this lens in SI units with sign convention is,
 (1). +50 D (2). -50D (3). +200D
 (4). -200D (5). +2D
04. The frequency of a vibrating string can be doubled by,
 (1). doubling the length ✗ (2). doubling the tension ✓ (3). halving the tension
 (4). increasing the tension by 4 times (5). increasing the length by 4 times
05. A spherometer is kept on a flat surface to level and the relevant measurement is shown in the figure (a) and same instrument is used to measure the thickness of a coin as shown in the figure (b). The thickness of the coin is,
 (1). 2.70 mm
 (2). 2.90 mm
 (3). 3.10 mm
 (4). 4.10 mm
 (5). 4.30 mm ✓
- 

(a)

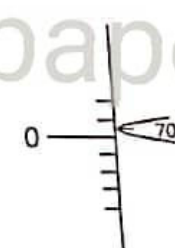

(b)
06. The monthly consumption of electricity in kWh when five bulbs of 60 W use 6 hours per day and an electric kettle of 1000 W use 10 min per day,
 (1). 5 (2). 30 (3). 54 (4). 59 ✓ (5). 64
07. When two forces act in the same direction, the magnitude of the resultant is twice that of the force in the opposite direction. The ratio of the magnitudes of the forces would be,
 (1). 1 (2). 2 ✓ (3). 3 (4). 4 (5). 5

08. The displacement - time graph of two objects X and Y are as follows.

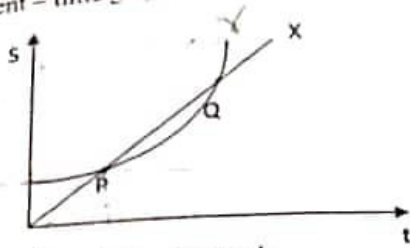

Consider the following statements on it.

- A. X passes Y at P.
- B. X passes Y at Q.
- C. Both start from rest and X moves with uniform velocity while Y moves under an acceleration.
- D. Velocities of X and Y are equal at P and Q.

The correct statement,

- (1). A only
- (2). B only
- (3). A and C only
- (4). C and D only
- (5). A, B and C only

09. The weight of an object on the surface of the earth is 800 N. When it moves a distance equal to the Earth's radius from the Earth's surface, its weight will be,

- (1). 200 N
- (2). 300 N
- (3). 400 N
- (4). 800 N
- (5). 1600 N

10. An object moving from rest with constant acceleration for a period of time acquires kinetic energy E. If the object moves from rest with an acceleration twice that acceleration for the same time, the kinetic energy acquired by the object is,

- (1). $\frac{E}{2}$
- (2). E
- (3). 2E
- (4). 4E
- (5). 8E

11. When the angular momentum of a rotating object increases by 20%, the percentage increase in its rotational kinetic energy is,

- (1). 20%
- (2). 24%
- (3). 36%
- (4). 44%
- (5). 64%

12. A particle moves in a horizontal circular path with uniform angular velocity. The physical quantity/ies signs that remain constant with time is/are,

- A. Velocity of the particle
- B. Kinetic energy of the particle
- C. Centripetal acceleration of the particle
- D. Angular momentum of the particle

- (1). A and B only
- (2). A and C only
- (3). B and D only
- (4). A, B and C only

(5). A, B, C and D All

13. An object of mass m rests on a rough plane inclined θ to the horizontal as shown in the figure. The coefficient of static friction between the object and the inclined plane is μ . The frictional force acting on the object is,

- (1). $mg \cos \theta$
- (2). $mg \sin \theta$
- (3). $\mu mg \cos \theta$
- (4). $\mu mg \sin \theta$
- (5). $\mu mg \tan \theta$

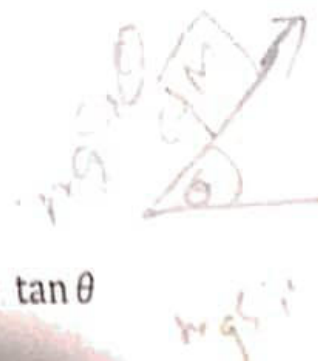

14. The figure shows a ray of light incident on a convex lens. After refraction, the rays pass through which of the following points?

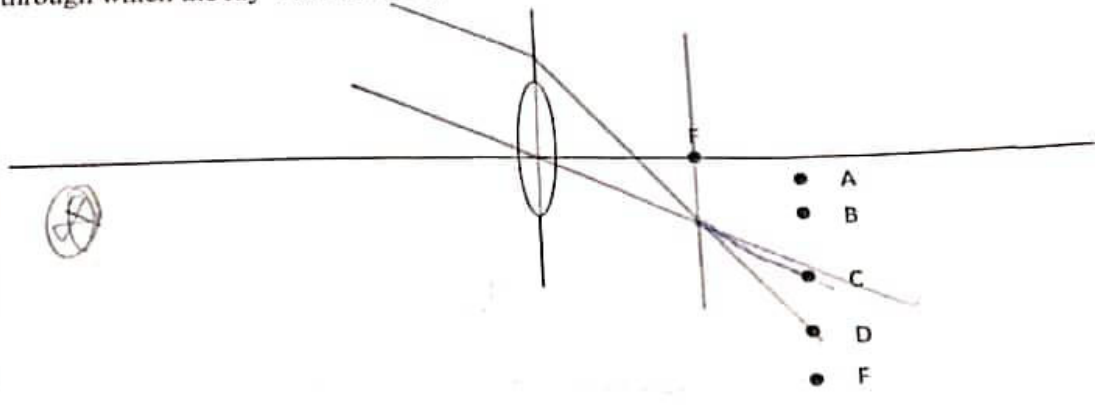

- (1).A (3).B (3).C (4).D (5).E

15. A constant force F is applied to an object at rest on a horizontal smooth plane as shown in the figure. The variation of the object's velocity (v) with displacement (s) is best represented by,

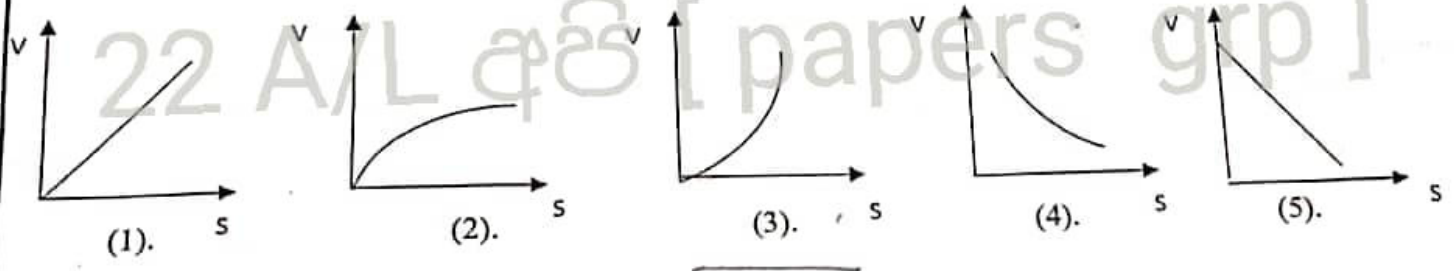

16. The path of a ray of light entering from point X the glass block shown in the figure, can be, (refractive index of glass = 1.5)

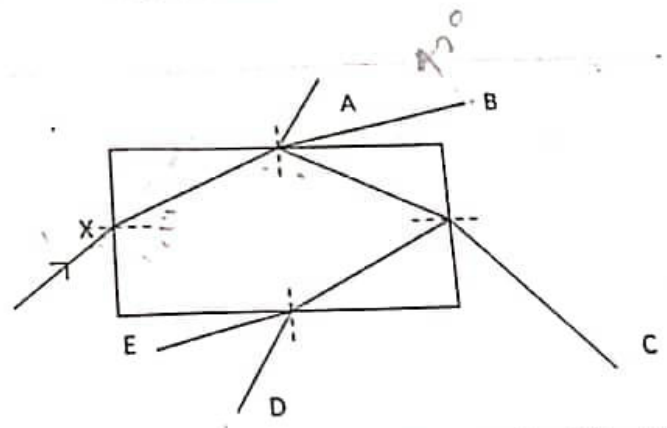

- (1).A
(2).B
(3).C
(4).D
(5).E

17. As shown in the figure, a uniform meter ruler AB is kept in equilibrium on a wedge 70 cm from the end A, by hanging a mass of 50 g from the end B. The mass of the meter ruler is,

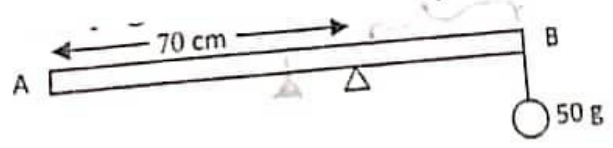

- (1).33 g (2).50 g (3).71 g (4).75 g (5).125 g

18. The displacement of an object that undergoes simple harmonic motion is given by $y = 0.30 \sin(220t + 0.64)$ Here t and y are measured in seconds and meters. Frequency of motion and maximum velocity respectively,
- (1). 45 Hz, 66 ms^{-1} (2). 58 Hz, 113 ms^{-1}
 (4). 35 Hz, 132 ms^{-1} (5). 55 Hz, 66 ms^{-1} (3). 35 Hz, 66 ms^{-1}

19. A ball is dropped from a height of 1.8 m onto a hard surface. The collision between the ball and the surface is perfectly elastic. If the ball bounces continuously on the surface, the motion of the ball is, ($g = 10 \text{ ms}^{-2}$)
- (1). is a simple harmonic motion of period 2.4 s.
(2). is a simple harmonic motion of period 1.2 s.
 (3). is a simple harmonic motion of period 0.6 s.
 (4). is a simple inelastic but periodic motion of period 0.6 s.
 (5). is a simple inelastic but periodic motion of period 1.2 s.

20. When relative motion occurs between a sound source and an observer, the source emits sound waves at a frequency of 100 Hz and the observer hears sound at a frequency of 90 Hz. If the speed of sound in air is 330 ms^{-1} , which statement is correct regarding the velocities of the source and the observer?
- (1). The source moves towards the stationary observer with a velocity of 36.7 ms^{-1} .
 (2). The observer moves towards the stationary source with a velocity of 33 ms^{-1} .
(3). The observer moves away from the stationary source with velocity 33 ms^{-1} .
 (4). The observer moves away from the stationary source with a velocity of 36.7 ms^{-1} .
 (5). The source moves away from the observer with a velocity of 33 ms^{-1} .

21. The picture shows part of a design made using uniform wire sections. The most likely point to be its center of gravity are,
- (1). A (2). B (3). C (4). D (5). E

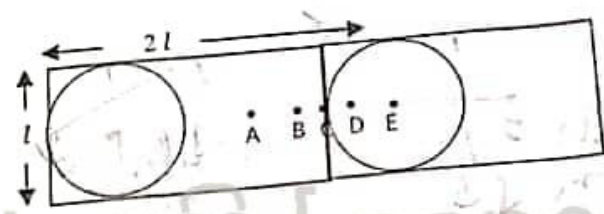

22. The variation of the external force on an object of mass 5 that kept on a smooth plane at rest, with time (t) is given below. If the velocity of the object after 5s is 18 ms^{-1} then the magnitude of F is,

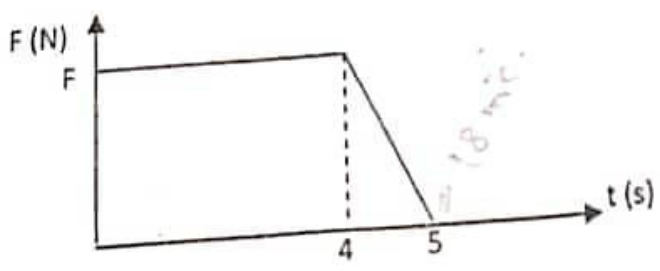

- (1) 18 N (2). 20 N (3). 22.5 N (4). 25.0 N (5). 27.5 N

23. There are three masses A, B and C on a smooth horizontal plane as shown in the figure and mass A is initially 20ms^{-1} moving in the right direction while B and C are stationary. After the collision between A and B, mass A moves in the left direction with a velocity of 4ms^{-1} . If the collision between B and C is perfectly elastic then the velocities of B and C after all collisions,

- (1). $0, 8\text{ms}^{-1}$
- (2). $0, 12\text{ms}^{-1}$
- (3). $6\text{ms}^{-1}, 6\text{ms}^{-1}$
- (4). $8\text{ms}^{-1}, 4\text{ms}^{-1}$
- (5). $12\text{ms}^{-1}, 0$

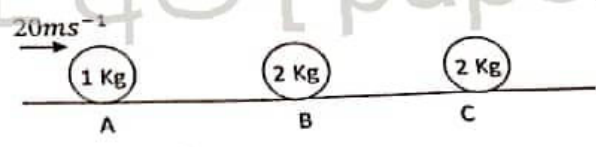

24. When a sonometer wire vibrates with a tuning fork, a beat can be heard when the length of the wire is 95 cm and 100 cm. If the beat frequency is 4 Hz, then frequency of the tuning fork is,

- (1). 142 Hz
- (2). 148 Hz
- (3). 152 Hz
- (4). 156 Hz
- (5). 60 Hz

25. The sound intensity level of a certain sound is 8 dB higher than the sound intensity level of another sound. The ratio of the sound intensities of the two sounds is,

- (1). 6.3
- (2). 0.63
- (3). 3.15
- (4). 31.5
- (5). 63

26. As shown in the figure, water is filled to a height of 12 cm in a glass bowl with a bottom of thickness 12 cm. The apparent shift between the bottom AB and the water glass interface seen above the water surface is,

(Refractive index of water = $4/3$
Refractive index of glass = $3/2$)

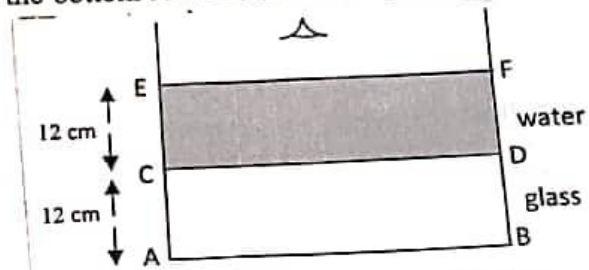

- (1) 4 cm
- (2) 5 cm
- (3) 7 cm
- (4) 8 cm
- (5) 9 cm

27. A string of mass 6 kg is 12 m long. A mass of 2 kg is attached to the end of the string and the string is hung vertically. A transverse wave of wavelength 0.06 m is pulsed at the lower end of the string. When it reaches the upper end of the string, the wavelength is,,

- (1). 0.04m
- (2). 0.06 m
- (3). 0.08 m
- (4). 0.12 m
- (5). 0.24 m

28. A certain oil is spread on a horizontal table to have a constant thickness of $1 \times 10^{-5}\text{m}$. A 0.1m^2 plate is placed on this area and moved with a speed of 11mms^{-1} . If the viscosity coefficient of the oil is $1.5\text{kg m}^{-1}\text{s}^{-1}$ then the power required will be,

- (1) 7.5 N
- (2) 3.75 N
- (3) 15 N
- (4) 30 N
- (5) 22.5 N

29. A closed tube contains air and resonates with a fundamental tone of 300 Hz. Which of the following statements is false?

- (1). As the temperature of the air in the tube increases, the fundamental frequency increases. ✓
- (2). First overtone frequency is 900 Hz. ✓
- (3). As the air pressure in the tube increases under constant density, the fundamental frequency increases. ✓
- (4). An open tube of the same fundamental frequency must be twice as long. ✓
- (5). When the the density of the gas under constant temperature, its fundamental frequency increases. ✓

30. The always the correct statement about type and focal length F of compound lens formed by contact of a thin convex lens of focal length F_1 and a thin concave lens of focal length $F_2 (< F_1)$ and is,
- (1). convex, $F > F_1$
 (2). convex, $F < F_1$
 (3). concave, $F > F_2$
 (4). concave, $F < F_2$
 (5). convex, $F_1 > F > F_2$

31. A soap bubble of radius 2 cm is inside a soap bubble of radius 3 cm. The radius of one soap bubble with an internal pressure equal to the internal pressure of the smaller bubble is,

- (1). 1 cm
 (2). 1.2 cm
 (3). 1.5 cm
 (4). 2.5 cm
 (5). 3.2 cm

32. When a sonometer wire and a note of frequency 480 Hz are sounded together, a beat frequency of 6 Hz is heard. When a small amount of wax was applied to one of the prongs, the beat frequency decreased by 4 Hz. The frequency of the acoustic wire is,

- (1). 472 Hz
 (2). 474 Hz
 (3). 476 Hz
 (4). 478 Hz
 (5). 482 Hz

33. An elastic uniform wire is suspended vertically from the ceiling. A mass is suspended from its lower end and the proportional limit of the wire is not exceeded. Which of the following statements is true:

- A) If the mass hanging from the wire is doubled, the strain is doubled. ✓
 B) If the length of the wire is doubled, the strain is doubled. ✗
 C) If the cross-sectional area is doubled, the strain in the wire is doubled.

The correct statement is,

- (1). A only
 (2). B only
 (3). C only
 (4). B and C only
 (5). A and C only

34. The far point is 75 cm from the eye of a person whose near point is 25 cm from the eye. The type and focal length of the lens to be worn by this person to observe objects at infinity and his range of vision after wearing it would be,

- (1). concave, 75 cm, from 18.75 cm to infinity ✓
 (2). concave, 8 cm, from 25 cm to infinity
 (3). concave, 75 cm, from 37.5 cm to infinity ✓
 (4). convex, 25 cm, from 25 cm to infinity
 (5). convex, 75 cm, from 18.75 cm to 75 cm ✗

35. The internal radii of the U tube shown in the figure are a_1 and a_2 . ($a_2 < a_1$)

The U tube is placed vertically and filled with water.

If the density of water is ρ and the surface tension is T ,

the difference h between the water levels is,

- (1). $\frac{2T}{\rho g} \left(\frac{1}{a_1 - a_2} \right)$
 (2). $\frac{2T}{\rho g} \left(\frac{1}{a_2} - \frac{1}{a_1} \right)$
 (3). $\frac{2T}{\rho g} \left(\frac{1}{a_1} - \frac{1}{a_2} \right)$
 (4). $\frac{2T}{\rho g} (a_1 - a_2)$
 (5). $\frac{2T}{\rho g} \left(\frac{a_1 - a_2}{a_1 + a_2} \right)$

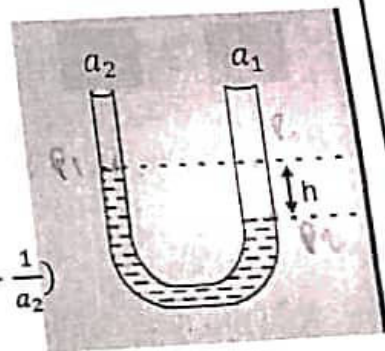

36. Two soap bubbles of radius r_1 and radius r_2 ($r_2 > r_1$) made of the same soap solution are stuck together. The radius of the common surface of the two bubbles is,

- (1). $\frac{r_1 r_2}{r_1 + r_2}$
 (2). $\frac{r_1 r_2}{r_2 - r_1}$
 (3). $\frac{r_2^2 - r_1^2}{r_1 r_2}$
 (4). $\frac{r_2 - r_1}{r_1 r_2}$
 (5). $\frac{r_1^2 + r_2^2}{r_1 r_2}$

37. The figure shows A water tank that three tubes of equal radii installed. While the height (h) between the tubes is the same. The water in the tank is filled to a constant height. Length of tubes are $l_1, 2l_1$ and $3l_1$ of tubes respectively from above. If the rate of volume of liquid flow are V_1, V_2, V_3 . The relation between V_1, V_2 and V_3 is,



1. $3V_1 = 2V_2 = V_3$
 4. $6V_1 = 2V_2 = V_3$

2. $6V_3 = 3V_2 = 2V_1$
 5. $3V_1 = 6V_2 = V_3$

3. $V_1 = V_2 = V_3$

38. The graph shows the variation of force (F) with displacement (x) when an object of mass 25 g is in simple harmonic motion. The frequency corresponding to this simple harmonic motion is,

- (1). $\frac{5}{\pi} \text{ Hz}$
 (2). $\frac{1}{10\pi} \text{ Hz}$
 (3). $\frac{10}{\pi} \text{ Hz}$
 (4). $\frac{2}{\pi} \text{ Hz}$
 (5). $\frac{1}{5\pi} \text{ Hz}$

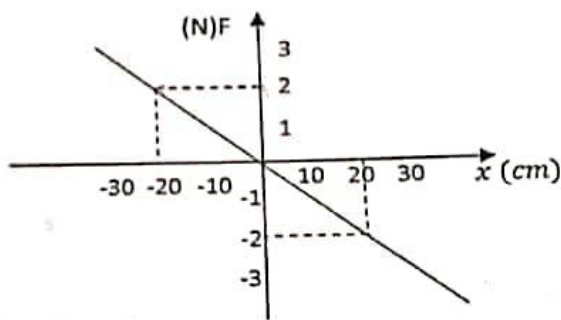

39. When n number of liquid drops of surface energy of each is E come together to form one drop,

- A) Energy is released. ✓
 B) Energy absorbed or released is $E(n-n^{2/3})$.
 C) The temperature of the single drop formed is lowered. ✓

The correct statement/s,

- (1). A only
 (2). B only
 (3). A and C ⊗ ⊗
 (4). A and B
 (5). A, B and C

40. A catapult is made using two rubber bands of cross-sectional area 5 mm^2 and length and 25 cm. Each rubber band is stretched to 30 cm long and a stone of mass 5 g is thrown. The initial velocity of the stone is, (Young's modulus of rubber- $2 \times 10^{11} \text{ Nm}^{-2}$)

- (1). $1 \times 10^3 \text{ ms}^{-1}$
 (2). $1.4 \times 10^3 \text{ ms}^{-1}$
 (3). $2 \times 10^3 \text{ ms}^{-1}$
 (4). $1.4 \times 10^2 \text{ ms}^{-1}$
 (5). $1 \times 10^2 \text{ ms}^{-1}$

41. A satellite passes near a planetary body of density d . Its period will be,

- (1). $\left(\frac{3\pi}{dG}\right)$
 (2). $\sqrt{\frac{3\pi}{dG}}$
 (3). $2\sqrt{\frac{3\pi}{dG}}$
 (4). $\sqrt{\frac{dG}{3\pi}}$
 (5). $\left(\frac{3\pi}{dG}\right)^{3/2}$

42. Two objects of masses m and $4m$ are at rest at an infinite distance from each other. When these two objects are moving towards each other under mutual gravitational forces, when they are separated by d .
- A) One object has zero velocity relative to the other. \checkmark
 B) The kinetic energy of each object is $\frac{4Gm^2}{d}$. \checkmark
 C) The total energy of the two objects is zero.
 D) The sum of the magnitudes of the velocities of the two objects is $\sqrt{\frac{10Gm}{r}}$. \checkmark
- the true statement/s.

- (1). A and B (2). B and C (3). A and D
 (4). B and D (5). B, C and D

43. Pipe segments AB, CD and EF are joined each other as shown in the figure to form a bowl. The radii of cross section of each section of a joined bowl are 10 cm, 60 cm and 20 cm respectively. The densities of the liquids present in those pipe sections are 800 kgm^{-3} , 1000 kgm^{-3} , 1200 kgm^{-3} respectively. The force exerts on the bottom FG of the body of liquid is, ($\pi = 3$)

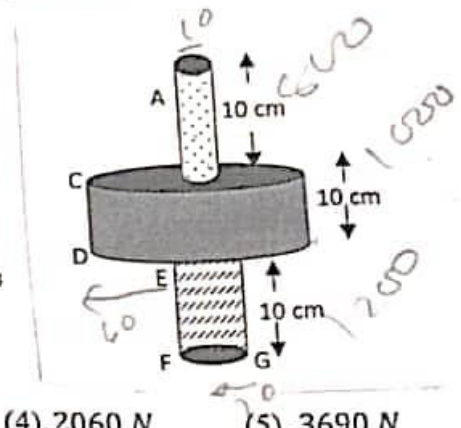

- (1). 360 N (2). 432 N (3). 1080 N (4). 2060 N (5). 3690 N

44. When an object is placed at a distance of 4 cm from a compound microscope made using two suitable convex lenses of focal lengths 2 cm, 5 cm and 10 cm, the angular magnification of the microscope is, (Minimum distance of distinct vision = 25 cm),

- (1). 5 (2). 6 (3). 10 (4). 18 (5). 25

45. P and Q are two steel wires. The diameter and length of p are double and triple of Q respectively. When equal tensile forces are applied to both the wires, the ratio of the elastic potential energies of the two wires P and Q is,

- (1) 1:1 (2). 4:3 (3). 1:2 (4). 3:4 (5). 2:1

46. Two metal and wooden blocks of equal volume of mass $4m$ and m respectively are kept in a fluid. Half of A is immersed in the fluid and the tension in the string to which B is attached is twice the tension in the string to which A is attached. The position of the blocks is best illustrated when they are freed from the strings and placed A on B and kept in the liquid,

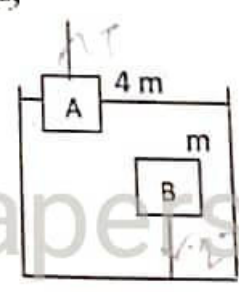

22 A/L [papers grp]

- (1) (2) (3) (4) (5)
-

ක/කැමිලා මධ්‍ය විද්‍යාලය - හොරණ
Taxila Central College - Horana

අධ්‍යයන පොදු සාහිතික පත්‍ර (උසස්පෙළ) විභාගය - 2023 - 13 ශ්‍රේණිය පළමු වාර පරීක්ෂණය
General Certificate of Education (Ad. Level) Examination, Grade 13

$$g = 10 \text{ Nkg}^{-1}$$

Part B - Essay

05. (a) i. Starting with the definition of the work, deduce the change in the gravitational potential energy of mass m , when moved a distance h upward against a gravitational field of strength g .
- ii. By using the equation of motion, show that the kinetic energy E_k of an object of mass m which starts from rest and obtain velocity of v in t period is given by, $E_k = \frac{1}{2}mv^2$

(b). A car is travelling along a horizontal road with constant speed V (ms^{-1}). The power $P(w)$, required overcome external forces opposing the motion is given by $P = CV + KV^3$ where C and K constants.

i. According to the above equation, theoretical velocity of the car could be a very high value. But practically obtaining a high velocity is not possible. Explain.

ii. Obtain the units of C and K in terms of base SI units.

iii. For one particular car, the numerical values of C and K in SI units are 300 and 0.8 respectively.

Calculate the power required to enable the car to travel along a horizontal road at 25ms^{-1}

iv. Calculate the magnitude of the external force opposing the motion of the car.

v. Coefficient of friction - find assumptions.

vi. Force of the car and oppose force for 5 mins.

vii. Total work done against (c) When the above car travels a distance of $1.2 \times 10^3 \text{ m}$ along the straight horizontal path, it reaches the bottom of an inclined path. A car starts moving uphill with an acceleration of 2 ms^{-2} to travel 15 km on this inclined road whose slope is 2:1.

i. If the coefficient of dynamic friction between this incline and the car is exactly half of the value calculated in b(v) above, what is the increase in the traction force of the car?

ii. What is the amount of work done by the car to reach the 15 km?

iii. Car consumes 1 liter of fuel to travel 15 km and burning 1 liter of fuel gives $12 \times 10^8 \text{ J}$ of energy.

1. Calculate the efficiency of the car's engine.

2. How much fuel does the car consume for the entire trip?

06. a. i. Write an expression for the gravitational potential at point P which is h high from the surface of the earth in terms of mass of the earth M . Radius of the earth R and universal gravitational constant G .

ii. Write an expression for the gravitational potential energy of a mass m is kept on the earth surface and the point P.

iii. Obtain an expression for minimum energy required to take that mass m from the earth surface to point p in terms of the given symbols.

iv. Deduce that the energy is mgh for $R \gg h$

v. The mass m is projected vertically upward with velocity v_1 from the point P .

(a) Write an expression for the total mechanical energy at point P .

(b) If the maximum height of the m is h_0 from the earth surface, then write an expression for h_0 using above symbols.

(c) Obtain an expression for the velocity of escape V_E at point P .

vi. If the mass m orbits around a circular path at height h from the earth surface with linear velocity V_2 . Express V_2 in terms of V_E .

vii. An object is projected from the surface of the earth in order to release from the gravitational field of the earth. Calculate the value of the minimum required velocity V_E' (Radius of the earth is 6400 km)

viii. If the mass of an air molecule is m and the Boltzman constant is K then the random velocity of an air particle (V) is given by, $V = \sqrt{\frac{3KT}{m}}$ Where T is the mean temperature of the earth.

(a) Calculate V for H_2 molecule. $K = 1.4 \times 10^{-23}$ $m = 3 \times 10^{-27} \text{ kg}$ $T = 280 \text{ K}$

(b) If a gas to exist in the atmosphere $V < (\frac{V_E}{6})$. Explain with reasons whether the gas H_2 exist in the atmosphere or not?

07. a. The load-extension diagram for two wires A and B of same material are shown below. A has a diameter of 0.4 mm and an undrawn length of 2.0 m.

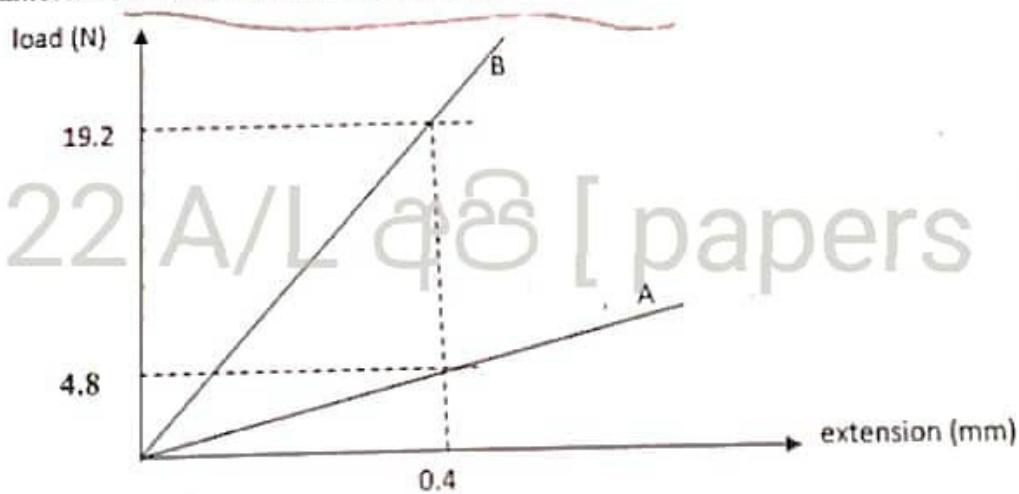

$r = 0.2 \times 10^{-3} \text{ m}$
 $r = 2 \times 10^{-4}$

i. Calculate the Young's modulus of A.

ii. Calculate the diameter of B if the undrawn length of B is 2.0 m.

iii. How many times is the energy stored in B as in A for a given load?

iv. What is the maximum load that can be applied so that the wire A does not break if the breaking elastic force of the material at A is $5 \times 10^8 \text{ Nm}^{-2}$?

v. If the two wires A and B are connected in series and drawn so that the total extension is 0.01 m,

1. Find the extensions of A and B.

2. Find the inclined force applied to the wire.

(b). i. Define surface tension force.

ii. A soap solution is placed in a U tube whose radii are unequal (r_1) and (r_2) ($r_1 > r_2$) so that the arms are vertical and fill it half full. Derive an expression for the difference in height between the two levels of the soap solution in the two arms. (Also take the surface tension force T and density ρ and contact angle to be zero.)

iii. Now a soap bubble of radius R is formed at the end of the large arm. Find the difference between the volumes of liquid on those arms. Find the surface energy stored in the soap bubble of radius R .

08. Answer part A or part B only.

Part A

(a) i. Define the oscillatory motion in terms of simple harmonic motion.

ii. A light helix spring of spring constant K is kept on a smooth floor and one end of the spring is attached to a fixed point and an object of mass m is attached to the other end as shown in the figure.

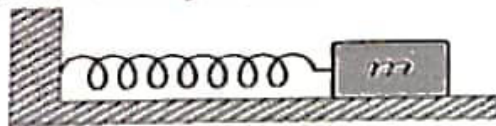

The object moves a small distance x horizontally and the release. Show that the object performs a simple harmonic motion.

iii. Obtain an expression for the period of oscillation of the object. Calculate the period of oscillation if the spring constant is 1000 Nm^{-1} and mass of the object attached is 100 g . ($\pi = 3$)

iv. If the amplitude of the simple harmonic motion is 20 cm , then calculate the maximum velocity, maximum acceleration and total energy of it.

(b) Now the mass attached to the object is removed and replaced combined object (A) that consist of a sound source and a detector. mass of the combined object is too 100 g and the frequency of the sound emit from the source 3200 Hz . The velocity of sound in air is 340 ms^{-1} .

i. If a stationary observer is standing in front of the source that perform simple harmonic motion, what would be the maximum and minimum frequencies observed by the observer?

ii. Calculate the maximum and minimum frequency that heard by the observer when the object A has moved half of the amplitude.

iii. Plot the variation of the observed frequency per one oscillation with time. At $t = 0$ the object A is at the oscillation center.

iv. Calculate the minimum velocity of the object A in order to hear the frequency as exact half as the actual frequency?

v. Calculate the frequency detected by the detector and the beat frequency detected due to the wave reflected from the observer.

(c).

- i. Plot the variation of sound Intensity (I), with the distance r measured from the source.
- ii. A sound source emits $1.5 \times 10^3 J$ energy in 4 s. Threshold of hearing $1 \times 10^{-12} Wm^2$, Threshold of pain $1 Wm^2$.
 - I. Calculate the sound intensity at a point 20 m away from the source.
 - II. What would be the sound intensity level at that point away from the source.
 - III. Calculate the distance that should move towards the source so that his ear gets pain.
- iii. Inside of the human ear can be considered as an open cylinder. When the source mentioned above emits a note of frequency 3400 Hz, he hears. The sound with maximum intensity. What would be the length of the cylinder part.

(B)

a.

- i. When an object P is placed in front of a lens A of focal length 15 cm, an inverted image twice as large as the object is formed on a screen S.
 1. What type of lens A is?
 2. What is the object distance?
 3. State the convention of sign you have used here.
- ii. Another object Q is placed in front of the lens A on the side opposite to the object P, such that the distance between P and Q is 32 cm. When the position of the lens A is slightly changed, the images of both objects P and Q are formed at the same point and the image of P is still real.
 1. Calculate the object distances for objects P and Q.
 2. Note the direction and distance to move the lens A.
 3. Find the position of the images and calculate the linear magnification of each image.
- iii. The object Q is replaced by a concave lens B of focal length 12 cm.
 1. Find the distance from A to the last image at P.
 2. Find the position of the final image of the object P when lens B is brought closer to lens A and contact A and B to form a composite lens.
 3. Are the image distances calculated in (iv) I and (iv) II above the same or not? Explain your answer.
- b. A man used lens A to correct his vision defect.
 - i. What visual defect was he suffering from?
 - ii. Draw the incidence and refraction of light ray on the defected eye.
 - iii. Draw the ray diagram after correcting for the error using lens A.
 - iv. If the minimum distance of distinct vision is 25 cm, find the distance to the near point of this person.
 - v. The diameter of this person's eyeball is 2.5 cm. Calculate the power of the eye lens when he observes an object at the near point. (Assume that the lens A worn by the man and the eye lens are very close to each other.)