

සියලු මුළු හිමිකම් ඇවිරිණි / முழுப் பதிப்புரிமையுடையது / All Rights Reserved

ශ්‍රී ලංකා විභාග දෙපාර්තමේන්තුව ශ්‍රී ලංකා විභාග දෙපාර්තමේන්තුව ශ්‍රී ලංකා විභාග දෙපාර්තමේන්තුව ශ්‍රී ලංකා විභාග දෙපාර්තමේන්තුව ශ්‍රී ලංකා විභාග දෙපාර්තමේන්තුව
 இலங்கைப் பரீட்சைத் திணைக்களம் இலங்கைப் பரීட்சைத் திணைக்களம் இலங்கைப் பரීட்சைத் திணைக்களம் இலங்கைப் பரීட்சைத் திணைக்களம் இலங்கைப் பரීட்சைத் திணைக்களம்
 Department of Examinations, Sri Lanka Department of Examinations, Sri Lanka Department of Examinations, Sri Lanka Department of Examinations, Sri Lanka Department of Examinations, Sri Lanka
 ශ්‍රී ලංකා විභාග දෙපාර්තමේන්තුව ශ්‍රී ලංකා විභාග දෙපාර්තමේන්තුව ශ්‍රී ලංකා විභාග දෙපාර්තමේන්තුව ශ්‍රී ලංකා විභාග දෙපාර්තමේන්තුව ශ්‍රී ලංකා විභාග දෙපාර්තමේන්තුව
 இலங்கைப் பரීட்சைத் திணைக்களம் இலங்கைப் பரීட்சைத் திணைக்களம் இலங்கைப் பரීட்சைத் திணைக்களம் இலங்கைப் பரීட்சைத் திணைக்களம் இலங்கைப் பரීட்சைத் திணைக்களம்
 Department of Examinations, Sri Lanka Department of Examinations, Sri Lanka Department of Examinations, Sri Lanka Department of Examinations, Sri Lanka Department of Examinations, Sri Lanka

අධ්‍යයන පොදු සහතික පත්‍ර (උසස් පෙළ) විභාගය, 2018 අගෝස්තු
 கல்விப் பொதுத் தராதரப் பத்திர (உயர் தரப் பரீட்சை, 2018 ஓகஸ்ட்)
 General Certificate of Education (Adv. Level) Examination, August 2018

10.08.2018 / 0830 - 1030

භෞතික විද්‍යාව I
 பௌதிகவியல் I
 Physics I

01 E I

පැය දෙකයි
 இரண்டு மணித்தியாலம்
 Two hours

Instructions:

- * This question paper consists of 50 questions in 12 pages.
- * Answer **all** the questions.
- * Write your **Index Number** in the space provided in the answer sheet.
- * Read the instructions given on the back of the answer sheet carefully.
- * In each of the questions 1 to 50, pick one of the alternatives from (1), (2), (3), (4), (5) which is **correct** or **most appropriate** and mark your response on the answer sheet with a cross (x) in accordance with the instructions given on the back of the answer sheet.

Use of calculators is not allowed.

(Acceleration due to gravity, $g = 10 \text{ N kg}^{-1}$)

1. Unit of pressure is
 (1) kg ms^{-2} (2) $\text{kg m}^2 \text{s}^{-2}$ (3) $\text{kg m}^{-1} \text{s}^{-2}$ (4) $\text{kg m}^2 \text{s}^{-3}$ (5) $\text{kg m}^{-2} \text{s}^{-2} \text{A}^{-1}$
2. X, Y and Z represent three physical quantities with **different** dimensions. They can be combined to form another physical quantity P of the form,

$$P = AX + BY + CZ$$
 Which of the following expressions has different dimensions from the rest?
 (1) AX (2) AX - CZ (3) $\frac{(AX)(CZ)}{BY}$ (4) $\frac{(BY)^2}{P}$ (5) (BY)(CZ)
3. Which of the following statements is **not** true?
 (1) LASER light consists of transverse waves.
 (2) Gamma rays are transverse waves.
 (3) Primary waves (P-waves) travelling through the crust of the Earth are longitudinal waves.
 (4) Ultrasound waves are longitudinal waves.
 (5) FM waves are longitudinal waves.
4. Consider the following statements made regarding the speed of sound v in an ideal gas.
 (A) v is directly proportional to the absolute temperature of the gas.
 (B) v is inversely proportional to the molar mass of the gas.
 (C) v depends on the ratio of the molar heat capacities γ for the gas.
 Of the above statements,
 (1) only A is true. (2) only C is true.
 (3) only A and B are true. (4) only B and C are true.
 (5) all A, B and C are true.
5. Which of the following statements made regarding optical instruments under normal adjustment is **not** true?
 (1) In a simple microscope, the image of the object is virtual.
 (2) When reading small letters using a simple microscope, a short-sighted person has an advantage over a long-sighted person.
 (3) In a compound microscope, the eyepiece acts as a simple microscope.
 (4) In a compound microscope, the final image is inverted.
 (5) In an astronomical telescope, the object distance and the image distance are both considered to be very large.

6. In a certain thermodynamic process in which an ideal gas is used, the increase of the internal energy of the gas is equal to the heat supplied to the gas. This process is
 (1) a cyclic process. (2) an adiabatic process.
 (3) a constant pressure process. (4) a constant volume process.
 (5) an isothermal process.
7. When the temperature of a metal rod is increased by $100\text{ }^\circ\text{C}$, its fractional change in length is 2.4×10^{-5} . The linear expansivity of the material of the rod is
 (1) $2.4 \times 10^{-3}\text{ }^\circ\text{C}^{-1}$ (2) $2.4 \times 10^{-4}\text{ }^\circ\text{C}^{-1}$ (3) $2.4 \times 10^{-5}\text{ }^\circ\text{C}^{-1}$
 (4) $2.4 \times 10^{-6}\text{ }^\circ\text{C}^{-1}$ (5) $2.4 \times 10^{-7}\text{ }^\circ\text{C}^{-1}$
8. A certain transformer has 900 turns in the primary coil and 30 turns in the secondary coil. When 240 V alternating voltage is applied across the primary coil, the voltage across the secondary coil is
 (1) 0 V (2) 8 V (3) 12 V (4) 72 V (5) 7.2 kV
9. Which of the following is **not** a source of e.m.f.?
 (1) Electrochemical cell (2) Photodiode (3) Piezoelectric crystal
 (4) Thermocouple (5) Charged capacitor

10. The logic circuit shown in figure (a) is equivalent to

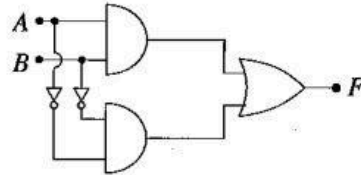
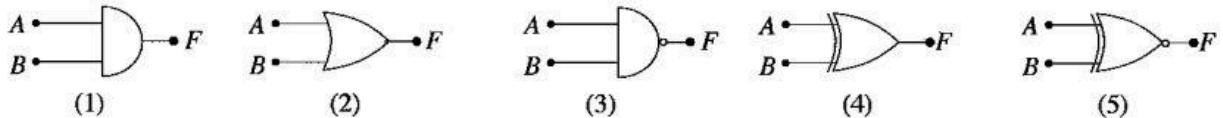
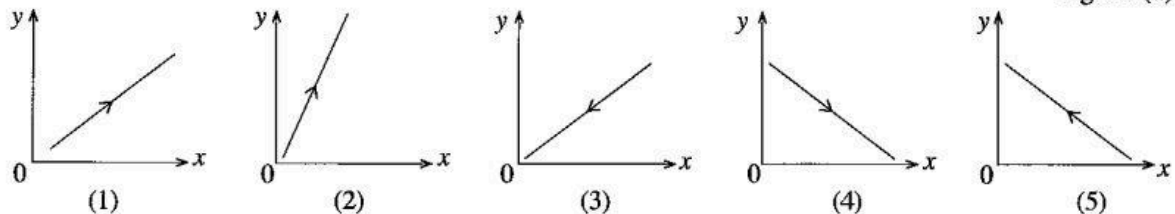
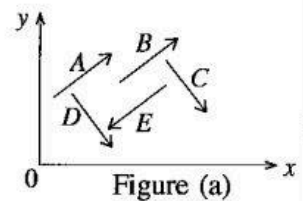

Figure (a)



11. The accelerations due to gravity on the surfaces of a uniform spherical planet A of radius R_A and a uniform spherical planet B of radius R_B are equal. If the mass of A is twice the mass of B,
 (1) $R_A = \sqrt{2}R_B$ (2) $R_A = 2R_B$ (3) $R_A = \frac{R_B}{\sqrt{2}}$ (4) $R_A = \frac{R_B}{2}$ (5) $R_A = R_B$
12. A, B, C, D and E are five coplanar forces of equal magnitudes acting on a body as shown in figure (a). Which of the following diagrams best represents the direction of the resultant of these forces?



13. An ant of mass $2 \times 10^{-6}\text{ kg}$ (2 milligrams), which is stationary at the edge of a horizontal smooth strip is removed in 0.2s by blowing with mouth. The direction of blowing is horizontal as shown by the arrows in the figure. If the ant is thrown out in the direction of the blowing with a horizontal velocity of 0.5 m s^{-1} , the average force exerted on the ant by the blow is
 (1) $5 \times 10^{-6}\text{ N}$ (2) $1 \times 10^{-5}\text{ N}$ (3) $2 \times 10^{-5}\text{ N}$ (4) $1 \times 10^{-3}\text{ N}$ (5) $5 \times 10^{-3}\text{ N}$

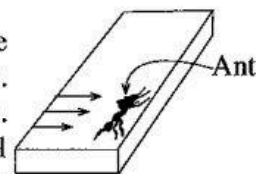

14. A small object of mass m placed on the horizontal surface of a frozen pond is given a kick imparting an initial speed v_0 along the horizontal direction. The object moves on the surface in a horizontal straight line without rotation. The coefficient of kinetic friction between the object and the surface is μ . If the air resistance can be neglected, the distance that the object moves before coming to rest is

- (1) $\frac{v_0^2}{2\mu g}$ (2) $\frac{v_0^2}{\mu g}$ (3) $\frac{2v_0^2}{\mu g}$ (4) $\frac{v_0^2}{2g}$ (5) $\frac{2v_0^2}{g}$

15. A coplanar structure is made by connecting eleven identical spheres each of mass m using ten identical light rods as shown in the figure. The centre of gravity of the structure is most likely to be at the point,

- (1) O
 (2) A
 (3) B
 (4) C
 (5) D

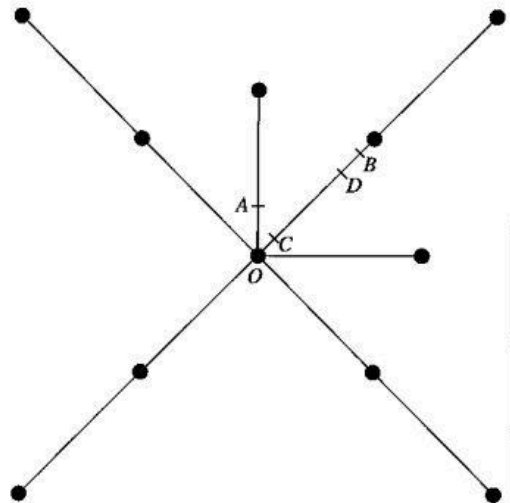

16. A block of mass 2 kg is pushed along a horizontal surface. The variation of the displacement x , of the block with time t , is shown in the figure. The values of the resultant force F acting on the block along the direction of motion during each of the time intervals $0 < t < 2$, $2 < t < 4$ and $4 < t < 5$ do not change. Which of the following correctly represents the magnitude of F in each of the time intervals?

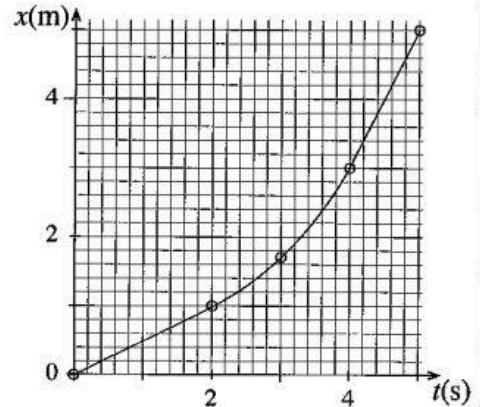

	$F(N)$ $(0 < t < 2)$	$F(N)$ $(2 < t < 4)$	$F(N)$ $(4 < t < 5)$
(1)	0	0	0
(2)	0	1.5	0
(3)	0	2	0
(4)	1	0	0
(5)	2	1.5	1

17. Figure shows a displacement (x) – time (t) curve for an object executing simple harmonic motion. For this motion, magnitudes of the period T , the frequency f , the angular speed ω , the maximum speed v_{\max} and the maximum acceleration a_{\max} are given by,

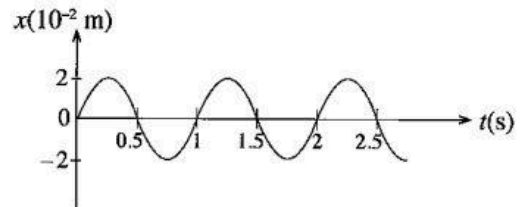

	$T(s)$	$f(Hz)$	$\omega (s^{-1})$	$v_{\max} \times 10^{-2} (m s^{-1})$	$a_{\max} \times 10^{-2} (m s^{-2})$
(1)	0.5	2	4π	4	16
(2)	1	1	2π	4π	$8\pi^2$
(3)	1	2π	2	4π	8
(4)	1	1	2π	8π	$16\pi^2$
(5)	1	1	4π	8	16

18. An elephant at rest is observed by a person 1 km away from his location. The sound intensity of trumpet of the elephant heard by the person is $10^{-10} \text{ W m}^{-2}$. Assume that the sound comes from a point source. If the threshold of hearing of the person is $10^{-12} \text{ W m}^{-2}$, what is the maximum distance from which he can hear this trumpet?
 (1) 1 km (2) 2 km (3) 4.5 km (4) 10 km (5) 20 km
19. Two mercury-in-glass thermometers P and Q are to be constructed with P having a larger bulb of mercury than that of Q , and both calibrated in the range $0^\circ\text{C} - 100^\circ\text{C}$. Assume that walls of both bulbs have the same thickness. Consider the following statements.
 Using capillary tubes with appropriate uniform bore radii, the two thermometers can be constructed to have
 (A) the same capillary length between 0°C and 100°C markings.
 (B) the same response time for rapid changes in the measuring temperature.
 (C) a higher sensitivity in thermometer P than the sensitivity of Q thermometer.
 Of the above statements,
 (1) only A is true. (2) only B is true.
 (3) only B and C are true. (4) only A and C are true.
 (5) all A, B and C are true.
20. Water at 0°C is continuously fed into a fully insulated boiler fixed with an immersion heater at a constant rate of $1 \times 10^{-2} \text{ kg s}^{-1}$. The specific heat capacity and the specific latent heat of vaporization of water are $4.2 \times 10^3 \text{ J kg}^{-1} \text{ }^\circ\text{C}^{-1}$ and $2.25 \times 10^6 \text{ J kg}^{-1}$ respectively. If the steam at 100°C is to be produced at the same rate as that of supply of water, the power of the immersion heater should be
 (1) 4.2 kW (2) 22.5 kW (3) 26.7 kW (4) 42.0 kW (5) 267.0 kW

21. In the circuit shown, value of each capacitor is $1 \mu\text{F}$. When the capacitors are fully charged, the total charge stored in capacitors is
 (1) $2 \mu\text{C}$ (2) $4 \mu\text{C}$ (3) $5 \mu\text{C}$
 (4) $8 \mu\text{C}$ (5) $10 \mu\text{C}$

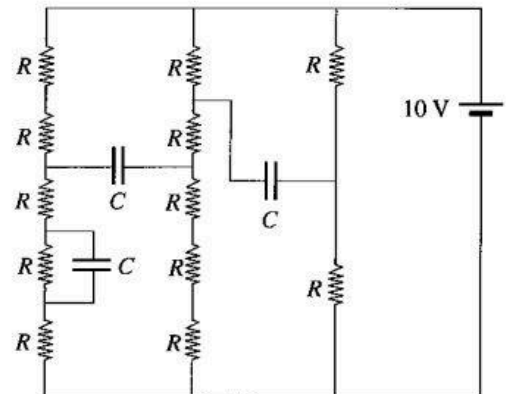

22. Figures show five clusters of soap bubbles in air, as drawn by a student. If centres of the bubbles in each cluster are coplanar, which of the following shows the cluster with physically possible correct shape?

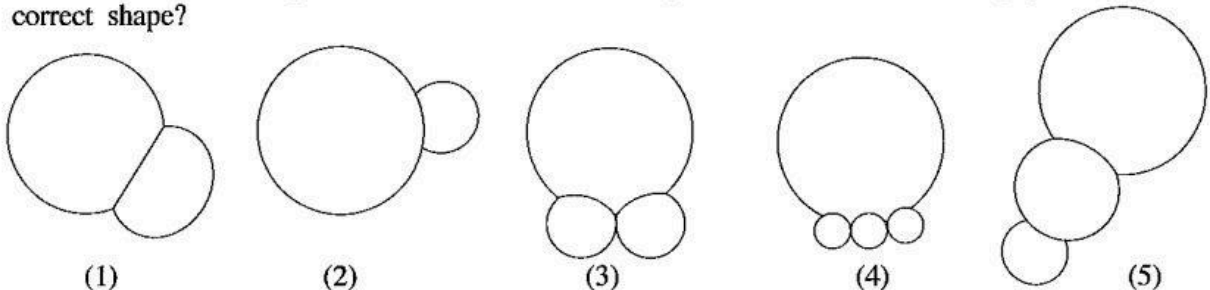

23. A Gaussian surface S is drawn enclosing a charge distribution of net positive charge as shown in the figure. If the electric flux through the portion of the surface marked as A is $-\psi$ ($\psi > 0$), which of the following is true regarding the electric flux ψ_R through the rest of the Gaussian surface?

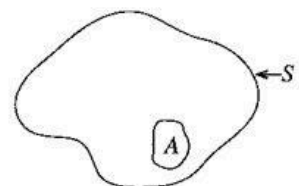

- (1) $\psi_R = -\psi$ (2) $\psi_R = +\psi$ (3) $\psi_R < -\psi$
 (4) $\psi_R < +\psi$ (5) $\psi_R > +\psi$

24. The three identical voltage sources in the circuits (A), (B) and (C), have a negligible internal resistance. In circuit (B), \odot represents a voltmeter having internal resistance r . If $R_3 = \frac{R_1 r}{R_1 + r}$, which of the following is true regarding I_1 , I_2 and I_3 shown in the circuits?

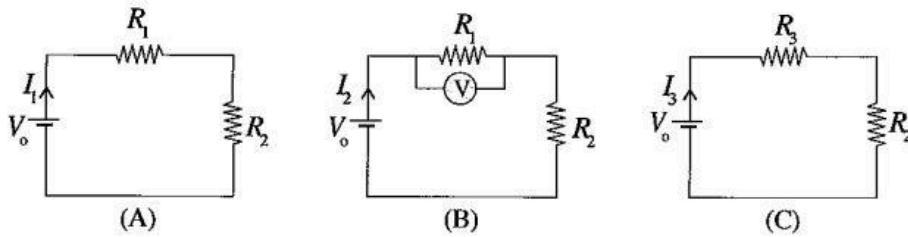

- (1) $I_1 = I_2 = I_3$
- (2) $I_1 > I_2 > I_3$
- (3) $I_1 > I_2 = I_3$
- (4) $I_2 = I_3 > I_1$
- (5) $I_3 > I_2 > I_1$

25. In the figure shown, $\square Z$ represents a network consisting of resistors of unknown values. If the internal resistance of the voltage source is negligible, the power dissipated by the network is

- (1) 60 mW
- (2) 90 mW
- (3) 120 mW
- (4) 150 mW
- (5) 180 mW

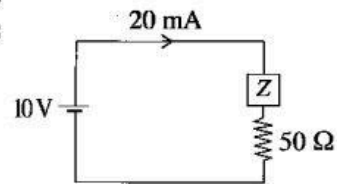

26. In the figure shown 1, 2, 3, 4, 5 and 6 represent six identical electric bulbs. Consider the operation of the circuit under conditions (A), (B) and (C) given below.

- (A) When bulb 2 is burnt.
- (B) When bulbs 2 and 5 are burnt.
- (C) When none of the bulbs are burnt.

Unburnt bulbs in the circuit can be seen glowing at the same brightness in,

- (1) B only.
- (2) C only.
- (3) A and C only.
- (4) B and C only.
- (5) all A, B and C.

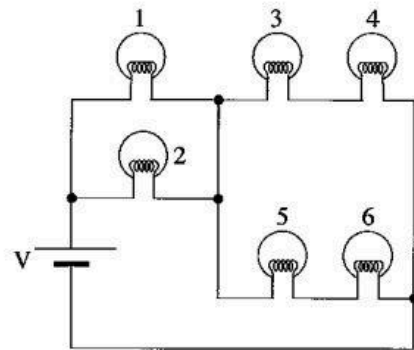

27. In the given circuit, the three 741 operational amplifiers ①, ② and ③ are operated by power supplies of $\pm 15V$, $\pm 10V$, and $\pm 8V$, respectively. The approximate values of the output voltages V_1 , V_2 and V_3 are respectively given by,

- (1) +2V, -4V, -4V
- (2) +15V, -10V, -8V
- (3) +2V, +4V, -4V
- (4) -15V, +10V, +8V
- (5) +15V, +10V, +8V

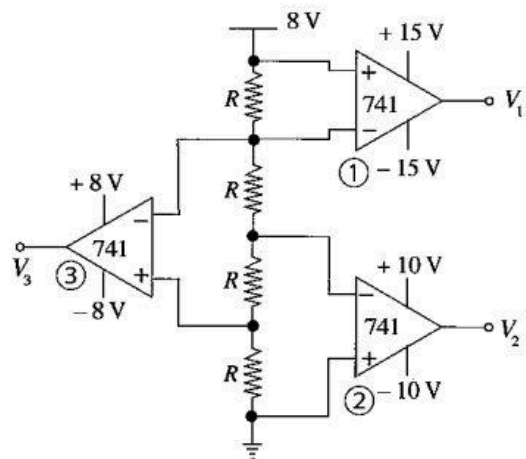

28. A uniform straight heavy plank of length $5l$ and mass $5m$ is kept horizontal on two supports separated by a distance $2l$ as shown in the figure. A painter of mass m needs to walk along the entire length of the plank carrying his bucket of paint. What is the maximum mass of the bucket of paint that can be carried by the painter without toppling the plank?

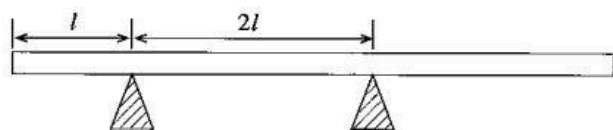

- (1) $\frac{15m}{2}$
- (2) $\frac{13m}{2}$
- (3) $\frac{5m}{4}$
- (4) m
- (5) $\frac{m}{4}$

29. Three tanks A, B, and C open at the top are initially filled with water to levels as shown in figure. They provide water at very slow speed to an outlet where static conditions could be applied. The two valves V_1 and V_2 allow water to flow only downwards when the pressure above the valve is greater than the pressure below the valve. When the system is put into operation with the initial conditions shown in the figure, which of the following statements best describes subsequent operation of the system?

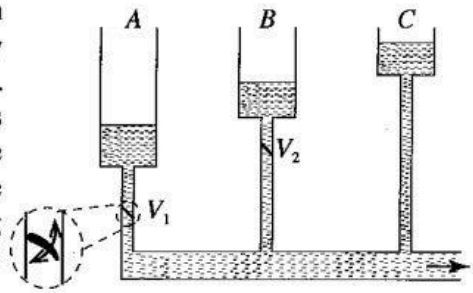

- (1) Only C will contribute to the flow at the outlet.
- (2) Initially, C starts to contribute to the flow at the outlet followed by B and then A in succession.
- (3) Initially, A starts to contribute to the flow at the outlet followed by B and then C in succession.
- (4) The three tanks will never contribute to the flow at the outlet simultaneously.
- (5) Initially, all three tanks contribute to the flow at the outlet with major contribution from C.

30. In an experiment to find Young's modulus, three different wires W_1 , W_2 and W_3 of the same material have been used and obtained three curves G_1 , G_2 and G_3 respectively for the graph of applied tensile force F with extension ΔL as shown in the figure. Which of the following statements, made for the reason of obtaining different graphs, is true?

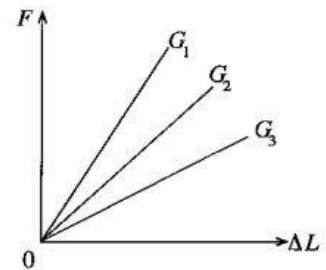

- (1) The wire W_1 may have a larger length and a smaller area of cross-section than W_2 .
- (2) The wire W_1 may have the same length as W_2 but a smaller area of cross-section than W_2 .
- (3) The wire W_3 may have the same area of cross-section as W_1 but a length larger than W_1 .
- (4) The wire W_2 may have a smaller area of cross-section, but a larger length than W_3 .
- (5) The wire W_3 may have a larger value for the ratio, $\frac{\text{Area of cross-section}}{\text{Length}}$ than that of W_1 .

31. A thin flat plate Z is placed midway between two large horizontal plates X and Y, and the space is filled with a viscous oil as shown in the figure. Now, consider a situation that the plate Z is pulled horizontally to the right with constant speed v and plate Y is pulled horizontally to the left with constant speed $\frac{v}{2}$ while keeping X stationary. The velocity vectors of thin oil layers between plates X and Y are best represented in,

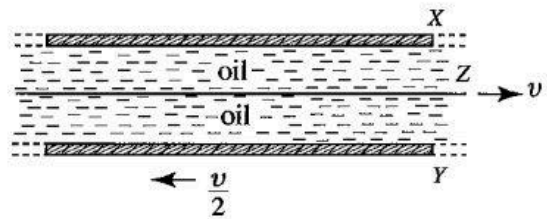

- | | | |
|------------|------------|------------|
| <p>(1)</p> | <p>(2)</p> | <p>(3)</p> |
| <p>(4)</p> | <p>(5)</p> | |

32. Radioactive element A_ZX transforms to stable ${}^{206}_{82}Pb$ after emitting eight α particles and six β^- particles in successive decays. The numbers of protons and neutrons in the element X respectively are

- (1) 92, 130
- (2) 92, 146
- (3) 92, 238
- (4) 104, 148
- (5) 146, 92

33. Consider a non-viscous and incompressible fluid moving with steady streamline flow through a tube of non-uniform cross-sectional area in a vertical plane. Figure shows the vertical cross-section of the tube. X, Y and Z represent three positions of a streamline. Area of cross-section of the tube at X is same as that at Z. Consider the following inequalities for the relative magnitudes of the kinetic energies per unit volume (KE_X, KE_Y, KE_Z), potential energies per unit volume (PE_X, PE_Y, PE_Z) and the fluid pressures (P_X, P_Y, P_Z) at the positions X, Y and Z respectively.

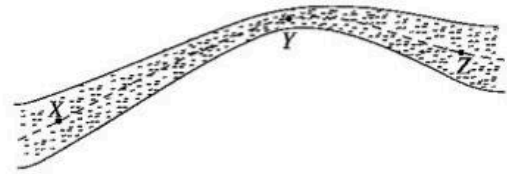

- (A) $KE_Z < KE_X < KE_Y$ (B) $PE_X < PE_Z < PE_Y$ (C) $P_Y < P_Z < P_X$

Of the above inequalities,

- (1) only A is true. (2) only B is true.
 (3) only A and B are true. (4) only B and C are true,
 (5) all A, B and C are true.

34. A disc freely rotates without friction at a certain angular speed, about a fixed vertical axis normal to the plane of the disc and passing through its centre. At time $t = 0$, a spider vertically lowers itself with negligible speed onto the rim of the rotating disc as shown in figure, and becomes rest. Variation of the magnitudes of the angular momentum (L) and the angular speed (ω) of the **disc only** with time (t) is best represented by,

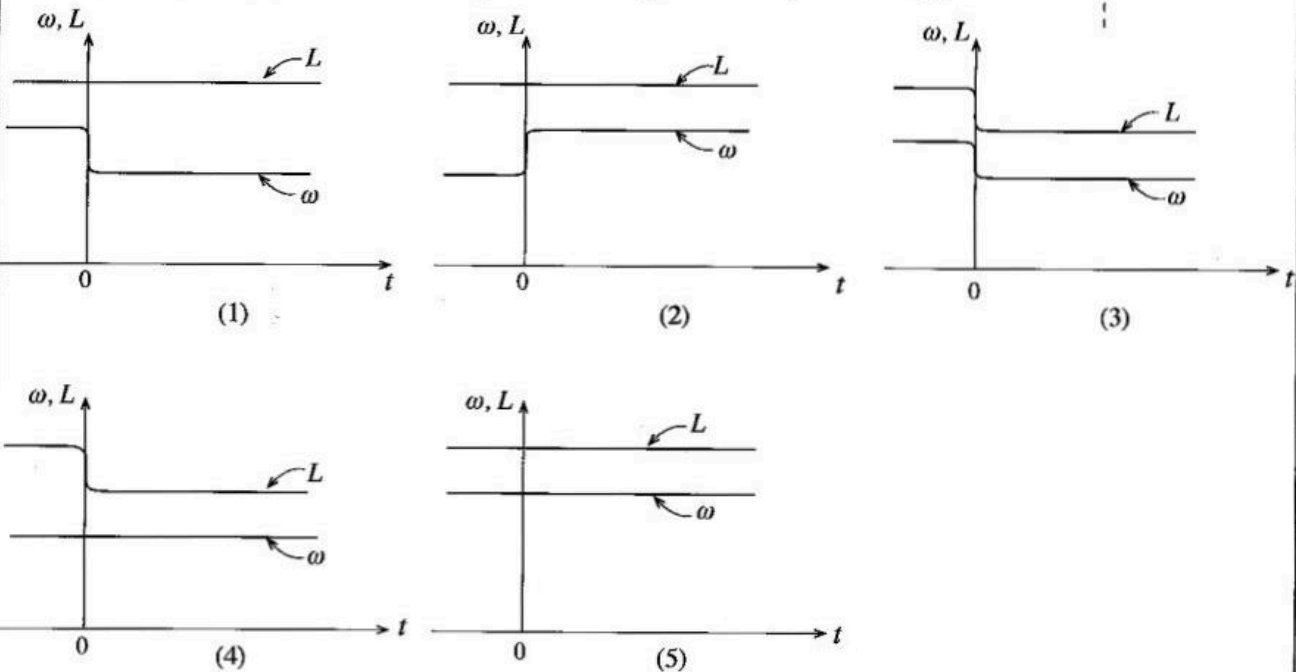
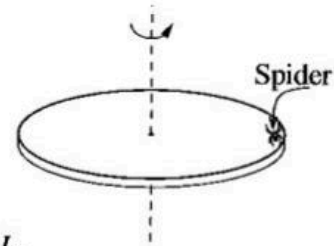

35. Figure shows vertical cross-sections of three uniform bodies A, B and C of identical masses. A is a solid sphere of radius r . C is a hollow sphere of radius r and having **thin walls**. The spheres can be rotated about vertical axes passing through respective centres. B is a disc of radius r which can be rotated about an axis normal to the plane of the disc passing through its centre. All figures are drawn to **same scale**. If KE_A, KE_B and KE_C respectively are the rotational kinetic energies to be provided for the bodies A, B and C to attain equal angular speeds, which of the following expressions is true?

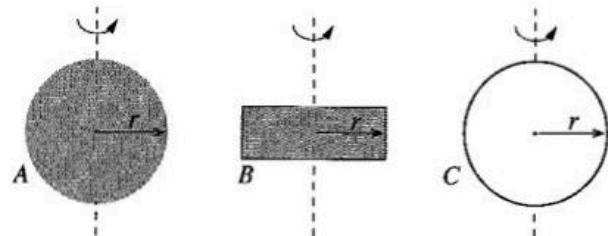

- (1) $KE_A < KE_B < KE_C$ (2) $KE_C < KE_A < KE_B$ (3) $KE_C < KE_B < KE_A$
 (4) $KE_A < KE_C < KE_B$ (5) $KE_A = KE_B = KE_C$

36. A whistle that is used to train a dog produces a frequency of 22 kHz which is more than the threshold of hearing of the human. The trainer of the dog wants to make sure that the whistle is working. While the trainer stands by the side of a long straight road, he asks a friend to blow this whistle from a car moving along the same road. The required speed of the car and the direction of motion of the car for the trainer to hear the whistle at his threshold of hearing of 20 kHz is (Speed of sound in air is 340 m s^{-1})
- (1) 31 m s^{-1} , away from the trainer. (2) 32 m s^{-1} , away from the trainer.
 - (3) 34 m s^{-1} , away from the trainer. (4) 32 m s^{-1} , towards the trainer.
 - (5) 34 m s^{-1} , towards the trainer.

37. Number 23 is written on a piece of paper placed on the flat horizontal surface of a table. A thin convex lens is held just above the number and then it is slowly taken vertically upward while looking at the image of the number through it, and keeping its optical axis vertical. Which of the following best represents the variation of the size and shape of the image as the lens is gradually moved up from the number 23?

- (1) 23.23.....23.23... (2) 23.23.....23.23...
- (3) 23.23.....23.23... (4) 32.32.....23.23...
- (5) 23.23.....23.23...

38. The hollow glass prism with thick walls as shown in figure, is made of a material of refractive index μ_g . A ray of monochromatic light PQ travelling in air is incident on the glass surface as shown in figure. In order to make the emergent ray travel along X, Y and Z directions respectively, the cavity of the hollow prism should be separately filled with transparent fluids of refractive index μ , where

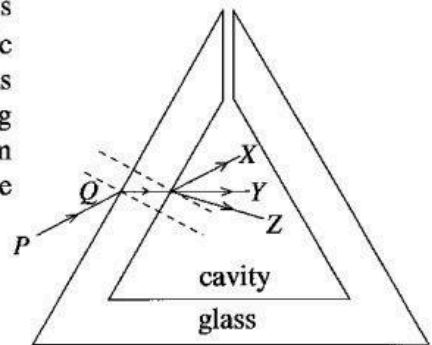

- (1) $\mu < \mu_g$, $\mu = \mu_g$, and $\mu > \mu_g$ respectively.
- (2) $\mu > \mu_g$, $\mu < \mu_g$, and $\mu = 1$ respectively.
- (3) $\mu = 1$, $\mu = \mu_g$, and $\mu < \mu_g$ respectively.
- (4) $\mu = 1$, $\mu < \mu_g$, and $\mu > \mu_g$ respectively.
- (5) $\mu = \mu_g$, $\mu = 1$, and $\mu = \mu_g$ respectively.

39. Biscuits of a freshly opened packet of biscuits were placed inside a container, and it was tightly closed with a lid, so that air cannot enter or leave the container. The initial relative humidity inside the container was also found to be 80%. After a few days, it was found that the relative humidity inside the container, had decreased to 30% and the mass of the biscuits had increased by m . If the temperature inside the container remained constant throughout, the mass of water vapour initially present inside the container was

- (1) $\frac{5m}{8}$ (2) $\frac{11m}{8}$ (3) $\frac{8m}{5}$ (4) $\frac{5m}{3}$ (5) $\frac{8m}{3}$

40. Figure shows how four thermally insulated heat conducting rods of equal lengths and equal cross-sectional areas are connected between two heat reservoirs maintained at temperatures 100°C and 0°C . A is a thermally insulated heat reservoir which always remains at constant temperature θ . The thermal conductivities k_1 , k_2 and k_3 of the rods are 10 , 30 and $50 \text{ W m}^{-1} \text{ K}^{-1}$ respectively. At the steady state, the temperature θ of the reservoir A is

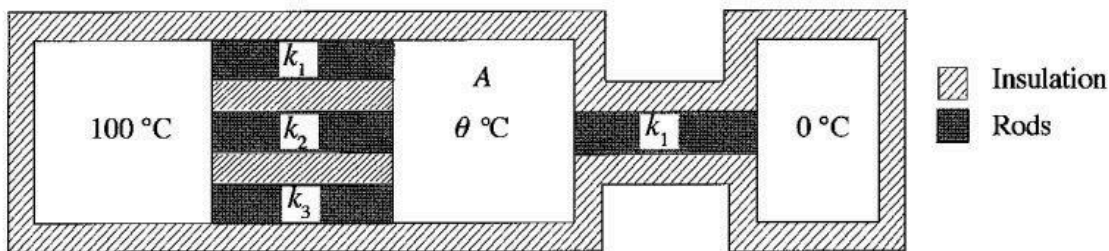

- (1) 90°C (2) 85°C (3) 80°C (4) 75°C (5) 65°C

41. A glass bottle of special shape, a vertical cross-section of which is shown in figure consists of a large cavity, a small spherical cavity of radius r and a narrow tapered tube of length l . The total volume of the large cavity and the half of the volume of the small cavity are initially filled with water at 0°C as shown. If the expansion of the bottle is **negligible**, the variation of height (h) of the water surface measured from the level XY , with the temperature of the water (θ) is best represented by

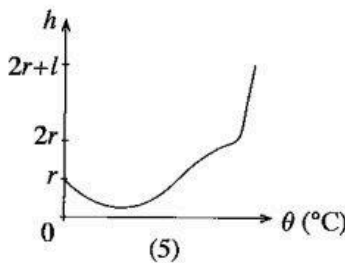
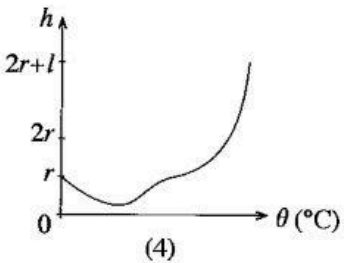
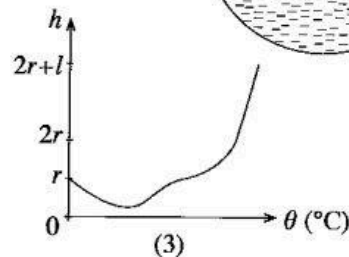
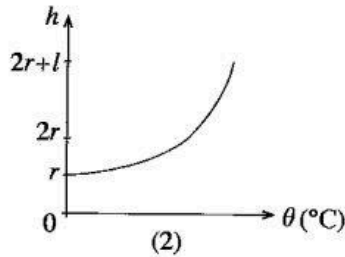
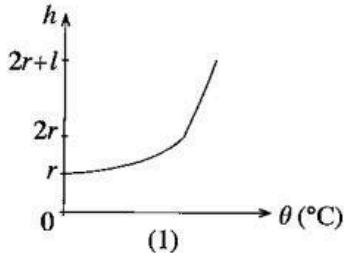
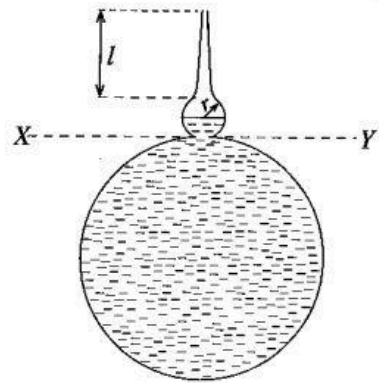

42. In the circuit shown in figure (a), the box with broken lines contains a resistor network. The 2V battery has a negligible internal resistance. An ideal voltmeter connected across ab gives a reading of 1V. When the voltmeter is replaced by an ideal ammeter it indicates 2 mA. The resistor network inside the box with broken lines is

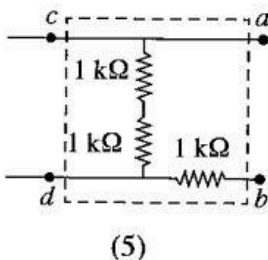
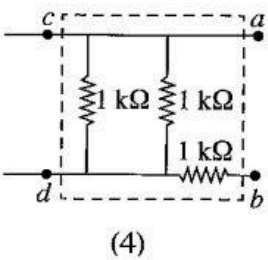
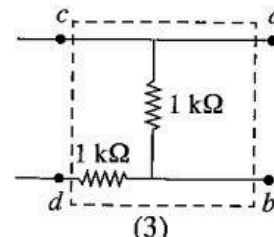
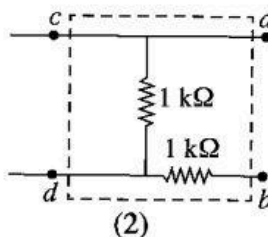
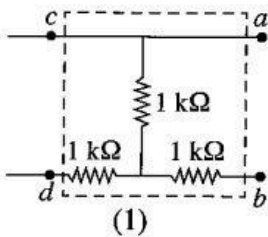
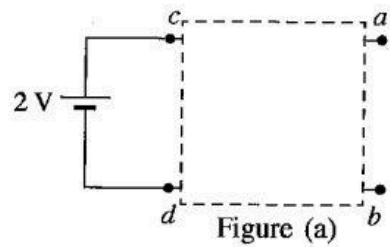

43. In the circuit shown, X and Y represent the terminals of a variable voltage source situated in the box with broken lines. P is a variable resistor. D is an ideal diode. As the value of the voltage V_X at point X is gradually increased from 0 to 15 V, which of the following graphs correctly represents the variation of the overall resistance R of the section of the circuit to the right of XY ?

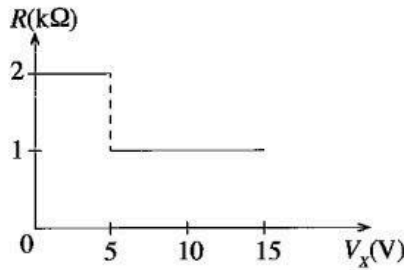
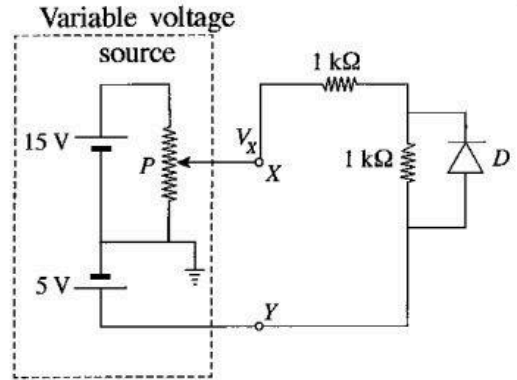

(1)

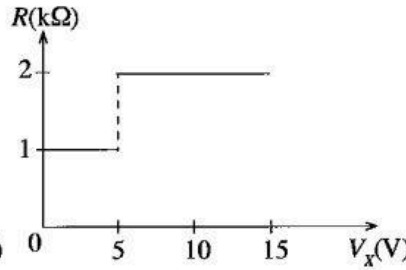

(2)

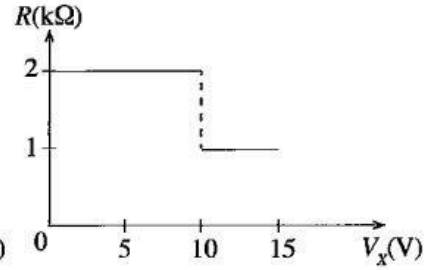

(3)

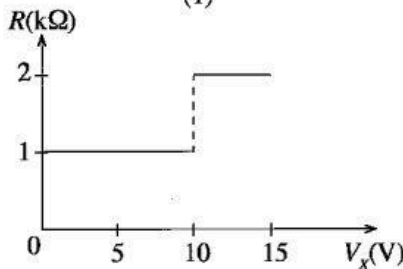

(4)

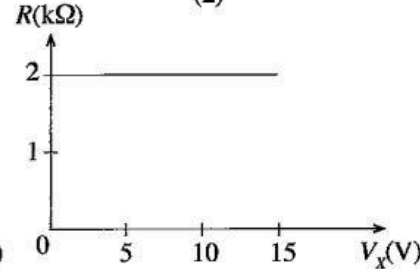

(5)

44. When a long capillary tube of uniform bore radius is dipped vertically in a beaker of water of density d_w , the water column in the capillary tube rises to a height h_0 as shown in figure (a). Now, an oil of density $d_0 (< d_w)$ is poured onto the surface of the water in the beaker slowly **without** disturbing the water as shown in figure (b). Assume that the oil and water are immiscible liquids. The variation of height H of the water column inside the capillary tube, measured from the water surface, with the height h of the oil layer is best represented in

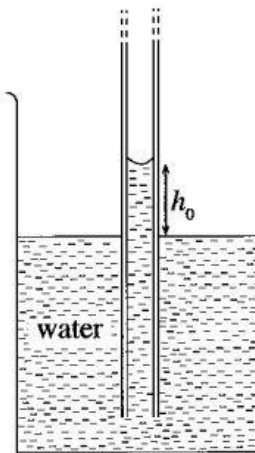

Figure (a)

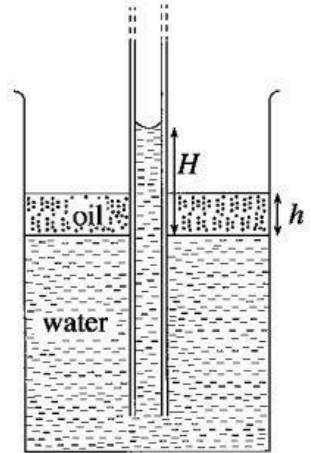
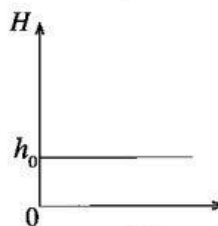
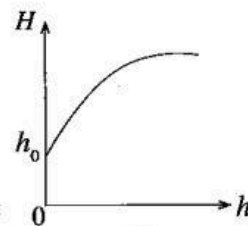

Figure (b)



(1)



(2)

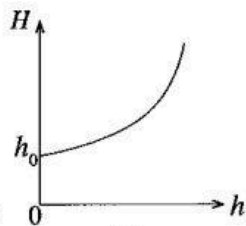

(3)

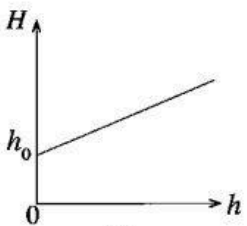

(4)

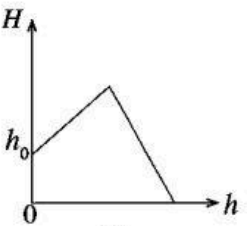

(5)

45. Charges in an isolated distribution of three $+q$ point charges are located at distances 2 cm, 3 cm and 6 cm from a point O . Another charge can be brought from infinity to the point O without doing any work once a point charge of $-q$ is placed at a distance r from the point O . The value of r is

- (1) 1 cm (2) 2 cm (3) 3 cm (4) 4 cm (5) 5 cm

46. Two teams start to play tug-of-war using a rope of uniform strength on a hard flat horizontal surface as shown in the figure. Both teams apply equal forces and as a result, the point O on the rope does **not** move. Consider the following statements made about this situation.

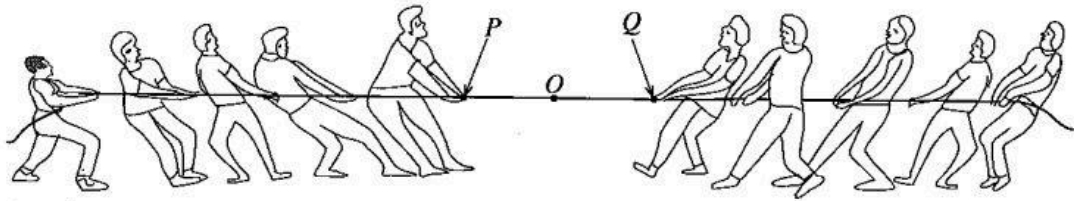

- (A) If each of the members of the two groups applies the same force on the rope, the magnitude of the tension throughout the rope is the same.
 (B) If the magnitude of tension on the rope exceeds its breaking tension, the rope will break only at a point between P and Q .
 (C) The magnitude of the maximum force that can be applied by an individual on the rope depends on the coefficient of static friction between feet of the individual and the surface.

Of the above statements,

- (1) only A is true. (2) only B is true.
 (3) only A and B are true. (4) only B and C are true.
 (5) all A, B and C are true.

47. Figure shows three objects (A), (B) and (C) which are made using three uniform wooden cubes of identical dimensions made out of the same material, and three identical uniform metal cubes. In (A) and (B) the metal cubes are glued onto the top and the bottom of the wooden cubes respectively. In (C), the metal cube is embedded in the wooden cube, as shown in the figure.

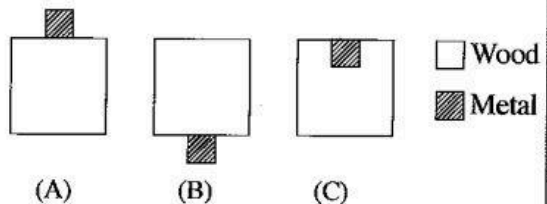

The three objects (A), (B) and (C) are now slowly lowered without changing their orientation and made to float vertically in a pool of water. If the depths to which the **wooden cubes** are immersed in water are H_A , H_B and H_C respectively, which of the following relationships is true?

- (1) $H_A > H_B > H_C$ (2) $H_A = H_B > H_C$
 (3) $H_A = H_B = H_C$ (4) $H_C > H_B > H_A$
 (5) $H_A > H_C > H_B$
48. An infinitely long thin straight wire held perpendicular to the plane of the paper at point O carries a current I into the paper as shown in the figure. Nine other similar infinitely long wires, parallel to the above wire, and held on the circumference of a circle of radius r with centre at point O , each carries a current I into the paper. Except for wires A and B , the angular separation between any two consecutive wires is 30° as shown. The magnitude and the direction of the magnetic force per unit length on the wire held at the centre O due to other wires are, (Take $\cos 30^\circ = \frac{\sqrt{3}}{2}$.)

- (1) $\frac{\mu_0 I^2}{2\pi r} (1 + \sqrt{3})$ in the direction of YO .
 (2) $\frac{\mu_0 I^2}{2\pi r} (1 + \sqrt{3})$ in the direction of OY .
 (3) $\frac{\mu_0 I^2}{\pi r} (1 + \sqrt{3})$ in the direction of OY .
 (4) $\frac{\mu_0 I^2}{2r} (1 + \sqrt{3})$ in the direction of OX .
 (5) $\frac{3\mu_0 I^2}{2\pi r}$ in the direction of YO .

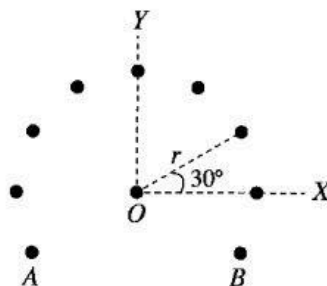

49. A toy car shown in figure (a) having an isolated metal axle PQ , travels with a constant speed v along a sinusoidal path whose vertical cross-section is in zx plane as shown in figure (b). At time $t = 0$, the axle PQ coincides with the y axis. If a uniform magnetic field of flux density B exists throughout the region in the $+z$ direction and normal to the xy plane, the variation of the induced e.m.f. (e) at end P of the axle with respect to end Q , with time (t) is best represented by, (Neglect the effect of the Earth magnetic field.)

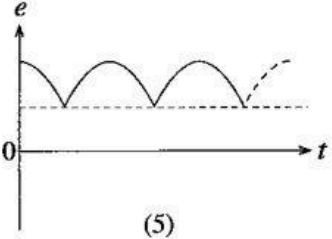
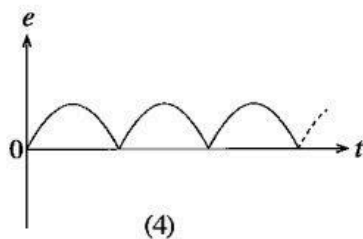
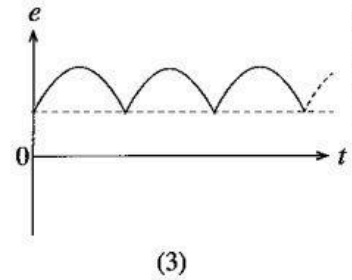
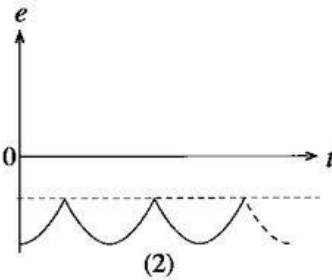
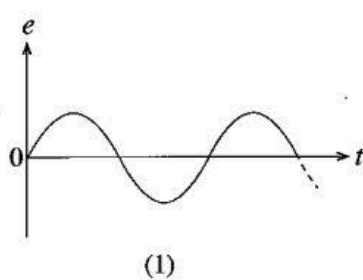
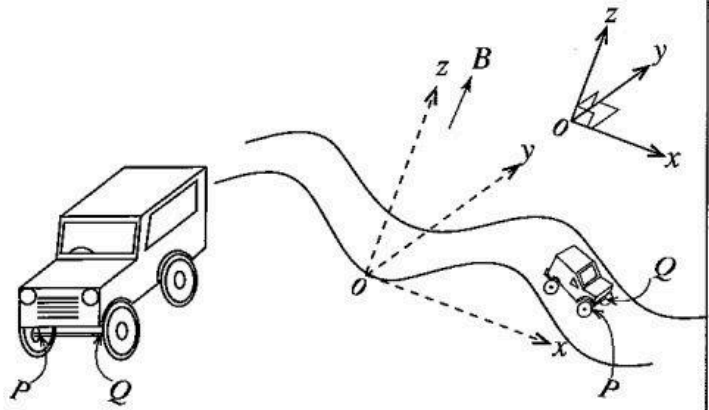

50. A, B, C and D represent vertical cross sections of four identical parallel rectangular metal plates placed normal to the plane of the paper. Each of the plates B, C , and D has a small hole at its centre. The three plates are arranged so that their holes are coaxially placed as shown in figure (a). Plate A is grounded and the entire system is in a vacuum. A stationary electron is created at time $t = 0$, at the position O on the axis through the holes as shown. Which of the voltages V_B, V_C and V_D should be applied to the plates to obtain the velocity (v) - time (t) curve shown in figure (b) for the electron? (Assume that the given voltages are suitable for practical use and that the edge effects and gravitational effects can be neglected.)

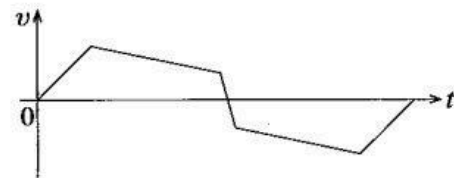
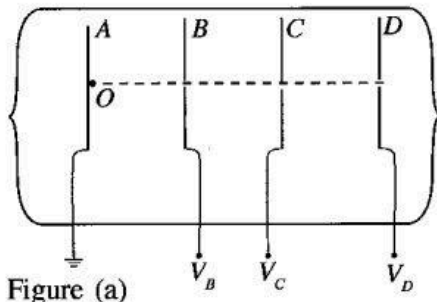

	V_B	V_C	V_D
(1)	- 3 kV	+ 2.6 kV	0 V
(2)	+ 2.5 kV	- 2.6 kV	+ 3 kV
(3)	+ 2.5 kV	+ 2.4 kV	+ 200 V
(4)	+ 3 kV	+ 2.6 kV	- 2.8 kV
(5)	+ 3 kV	+ 3.2 kV	- 2.2 kV

සියලු ම හිමිකම් ඇවිරිණි / முழுப் பதிப்புரிமையுடையது / All Rights Reserved

ශ්‍රී ලංකා විභාග දෙපාර්තමේන්තුව ශ්‍රී ලංකා විභාග දෙපාර්තමේන්තුව ශ්‍රී ලංකා විභාග දෙපාර්තමේන්තුව ශ්‍රී ලංකා විභාග දෙපාර්තමේන්තුව
 இலங்கைப் பரீட்சைத் திணைக்களம் இலங்கைப் பரීட்சைத் திணைக்களம் இலங்கைப் பரීட்சைத் திணைக்களம் இலங்கைப் பரීட்சைத் திணைக்களம்
 Department of Examinations, Sri Lanka Department of Examinations, Sri Lanka Department of Examinations, Sri Lanka Department of Examinations, Sri Lanka
 இலங்கைப் பரීட்சைத் திணைக்களம் இலங்கைப் பரීட்சைத் திணைக்களம் இலங்கைப் பரීட்சைத் திணைக்களம் இலங்கைப் பரීட்சைத் திணைக்களம்
 Department of Examinations, Sri Lanka

අධ්‍යයන පොදු සහතික පත්‍ර (උසස් පෙළ) විභාගය, 2018 අගෝස්තු
 கல்விப் பொதுத் தராதரப் பத்திர (உயர் தர)ப் பரீட்சை, 2018 ஆகஸ்ட்
 General Certificate of Education (Adv. Level) Examination, August 2018

භෞතික විද්‍යාව II
 பெளதிகவியல் II
 Physics II

01 E II

13.08.2018 / 0830 - 1140

ෆය තුනයි
 மூன்று மணித்தியாலம்
 Three hours

අමතර කියවීමේ කාලය - මිනිත්තු 10 යි
 மேலதிக வாசிப்பு நேரம் - 10 நிமிடங்கள்
 Additional Reading Time - 10 minutes

Use **additional reading time** to go through the question paper, select the questions and decide on the questions that you give priority in answering.

Index No. :

Important :

- * This question paper consists of 16 pages.
- * This question paper comprises of two parts, Part A and Part B. The time allotted for both parts is three hours.
- * Use of calculators is not allowed.

PART A – Structured Essay :
 (pages 2 - 8)

Answer **all** the questions on this paper itself.
 Write your answers in the space provided for each question. Note that the space provided is sufficient for your answers and that extensive answers are not expected.

PART B – Essay :
 (pages 9 - 16)

This part contains six questions, of which, four are to be answered. Use the papers supplied for this purpose.

- * At the end of the time allotted for this paper, tie the two parts together so that Part A is on top of Part B before handing them over to the Supervisor.
- * You are permitted to remove **only Part B** of the question paper from the Examination Hall.

For Examiners' Use Only

For the second paper		
Part	Question Nos.	Marks Awarded
A	1	
	2	
	3	
	4	
B	5	
	6	
	7	
	8	
	9 (A)	
	9 (B)	
	10 (A)	
	10 (B)	
Total		

Final Marks

In numbers	
In words	

Code Numbers

Marking Examiner 1	
Marking Examiner 2	
Marks checked by	
Supervised by	

PART A – Structured Essay

Answer *all four* questions on this paper itself.

(Acceleration due to gravity, $g = 10 \text{ N kg}^{-1}$)

Do not write in this column

1. An experimental setup of Hare's apparatus used in a school laboratory is shown in figure (1). As shown, x_w and x_l represent the heights to the mark M of the relevant indicator from the water and liquid surfaces in the beakers respectively.

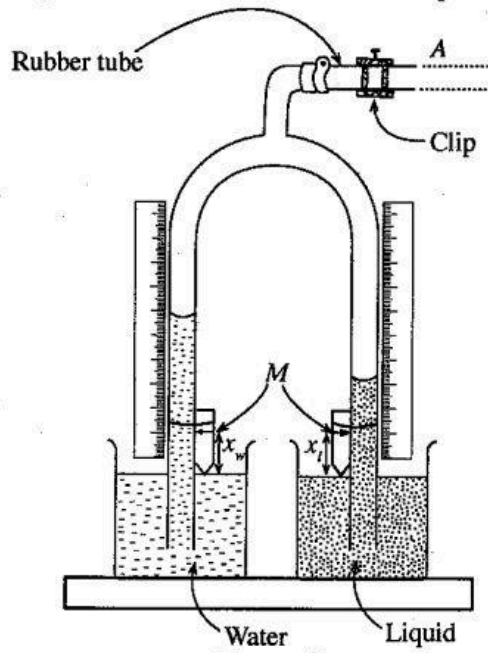

Figure (1)

- (a) (i) What is the purpose of using a clip in Hare's apparatus?

.....

- (ii) The densities of water and the liquid are d_w and d_l respectively. If h_w and h_l represent the heights of the water column and the liquid column in glass tubes as measured from the mark M of the respective indicators, derive an expression for h_l in terms of h_w , d_w , x_w , d_l , and x_l .

.....

.....

.....

.....

- (iii) If the expected heights of the liquid column and the water column are significantly different to each other, more attention has to be paid on one height than the other when planning out the experiment to take a set of readings and plot a graph. What is the height you pay more attention (one with a smaller height or larger height)? Explain your answer giving reasons.

.....

.....

- (iv) Every time after changing the heights of liquid and water columns in tubes and closing the clip you need to make another adjustment before taking the measurements with regard to new heights. Write down the experimental procedure which you should follow to make this adjustment.

.....

.....

Do not write in this column

(b) The apparatus shown in figure (2) can be used to vary the air pressure inside the tubes of the Hare's apparatus. This system works on Bernoulli's principle. The air pressure inside the tube *T* can be changed by adjusting the speed of the narrow water jet passing through the section *X* of the apparatus with the help of the tap. The position *A* of the apparatus shown in figure (2) can be connected to the position *A* of the rubber tube shown in figure (1), to make an improved version of Hare's apparatus.

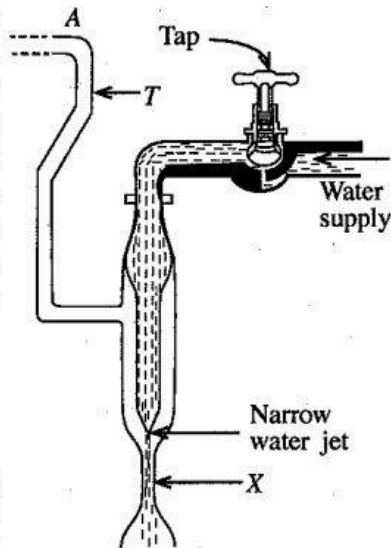

Figure (2)

(i) Write down the procedures used in Hare's apparatus available in the school laboratory, and improved version of Hare's apparatus mentioned in (b), when **establishing** the liquid columns in the tubes.

Hare's apparatus available in the school :

.....

Improved version of the Hare's apparatus :

.....

(ii) Give **one** main advantage of using the improved setup mentioned in (b) over the apparatus generally available in the school laboratory.

.....

(c) A graph plotted using a set of readings obtained from the improved apparatus, mentioned in (b) above, is shown below. The graph shows the variation of the heights h_w and h_t of the liquid columns for water and sulphuric acid respectively.

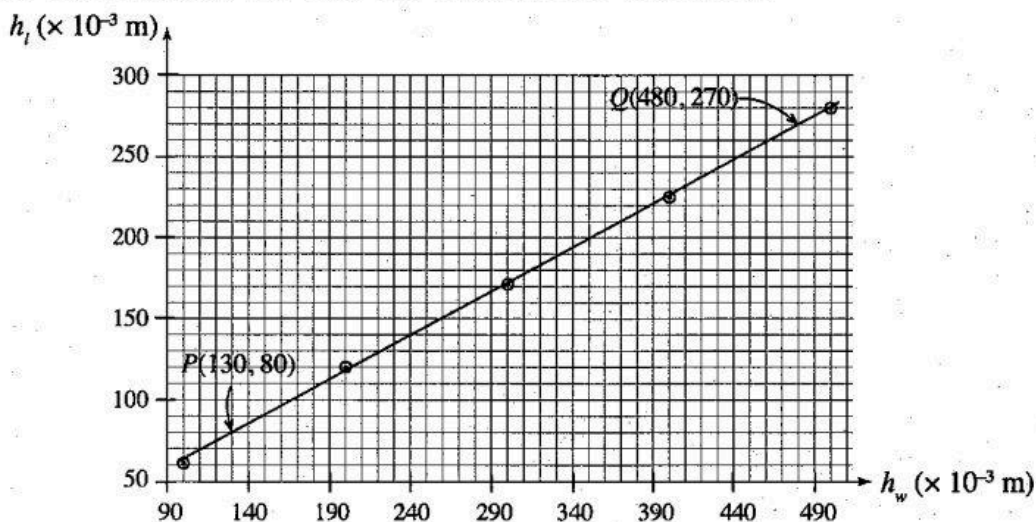

(i) In this experiment you are provided with a scale which can measure the length with an accuracy of 1 mm. What is the maximum **fractional** error associated with h_w measurements taken in this experiment?

.....

.....

(ii) Using the two points *P* and *Q* on the graph, calculate the relative density of sulphuric acid.

.....

.....

Do not write in this column

2. Figure (1) shows an **incomplete** diagram of an experimental setup that can be used to verify Charles's law.

(a) Upto what level *A*, *B*, *C* or *D* should water be filled in the cylinder in order to perform the experiment accurately?

.....

(b) Draw in figure (1), the important missing item, in the incomplete diagram (with appropriate size) other than water that you would require in this experiment.

(c) Give **two** advantages of using a mercury thread over a water thread in this experiment.

(i)

(ii)

(d) As the temperature is increased, mercury thread will also expand. Explain why this expansion does **not** affect the pressure of the trapped air column.

.....

(e) In this experiment, you are asked to measure the length (l_θ) of the trapped air column and its temperature (θ °C). Write down the main steps in the experimental procedures which you should follow to ensure that (i) the thermometer reading itself provides the temperature of the trapped air column, and (ii) length l_θ itself is the exact length corresponding to θ °C.

(i) Experimental procedure:

.....

.....

(ii) Experimental procedure:

.....

.....

(f) If the lengths of the dry air column trapped inside the capillary tube of uniform bore diameter at 0°C and θ °C are l_0 and l_θ respectively, write down an expression for l_θ in terms of γ_p , l_0 and θ , where γ_p is the volume expansivity at constant pressure for dry air.

.....

.....

(g) Draw a rough sketch of the expected graph with l_θ on the y-axis and θ in °C on the x-axis.

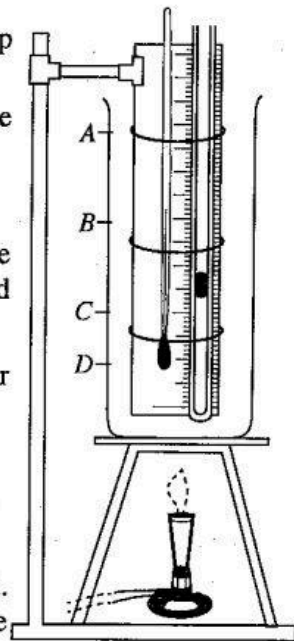
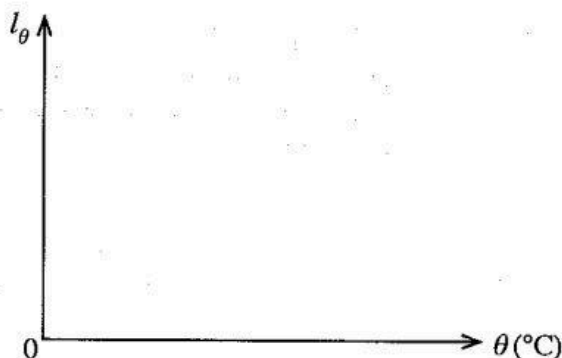

Figure (1)

(h) A student decided to use the capillary tube shown in figure (2)(a) instead of the tube shown in figure (2)(b) in this experiment. When taking a set of readings, is it more advantageous or more disadvantageous? Explain your answer.

.....

.....

.....

.....

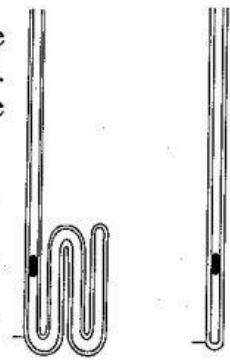

Figure 2(a) Figure 2(b)

Do not write in this column

(i) Can you perform this experiment properly using an electric hot plate instead of a Bunsen burner? Explain your answer.

.....

.....

3. You are asked to find the refractive index of glass using a rectangular block of glass and a travelling microscope. A small amount of lycopodium powder and a piece of white paper cut to the size of the glass block are also provided. A letter 'X' is marked in the middle of the white paper. Diagram of a travelling microscope that can be used in this experiment is shown in figure (1).

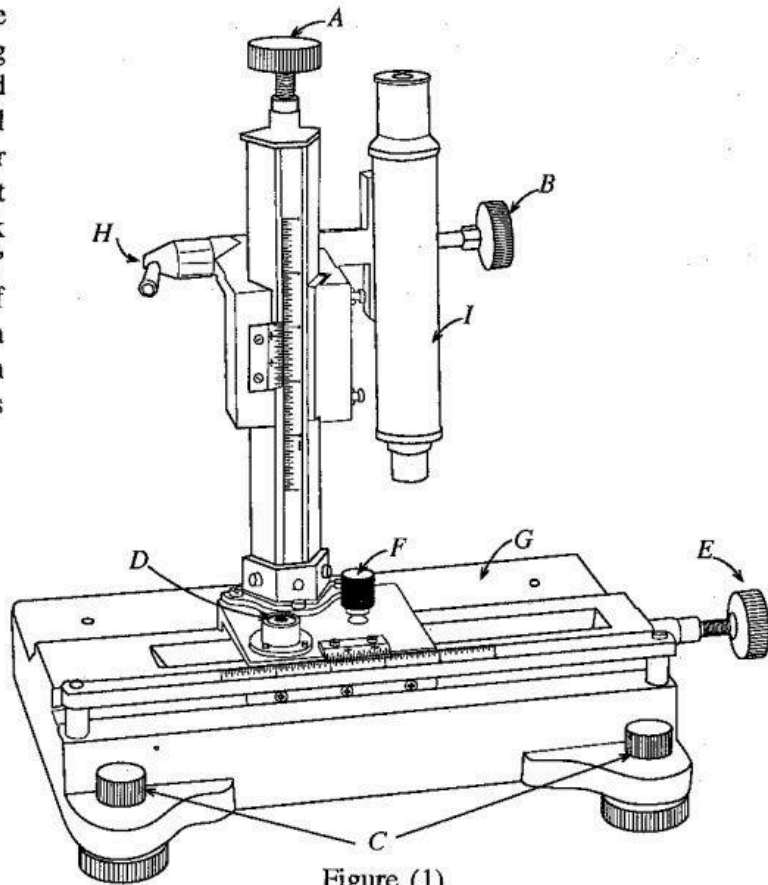

Figure (1)

(a) Identify the parts marked with A, B, C and D, and briefly state their functions.

Part	Identification	Function
A
B
C
D

Do not write in this column

(f) The output of the photodiode circuit in figure (D) is now connected to the input of the circuit shown below. Number of turns in the primary and the secondary coils in the transformer are 25 and 750 respectively. Assume that the value of capacitance C is very large. Take Zener voltage, $V_z = 75$ V.

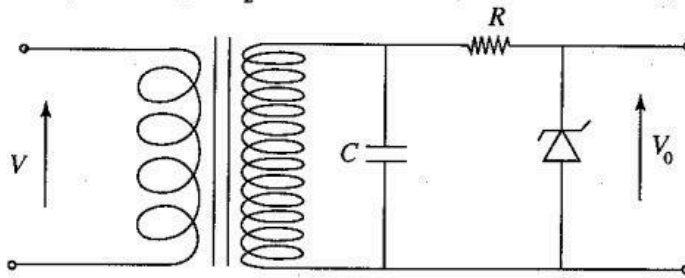

(i) What type of transformer is used in the above circuit?

.....

(ii) What is the value of the voltage that can be expected across the Zener diode?

.....

(iii) Draw a rough sketch to show how the output voltage V_0 varies with time t . Indicate the magnitude of the output voltage on the V_0 axis.

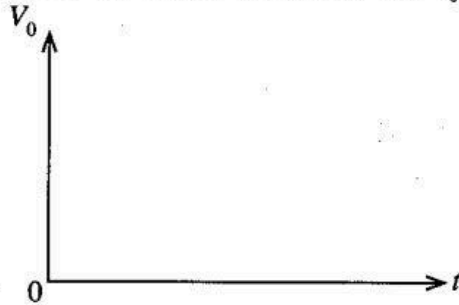

(g) A student argues that the experiment described above has provided a method to construct a dc to dc voltage converter. Would you agree with this argument? Explain your answer.

.....

* *

සියලු ම හිමිකම් ඇවිරිණි / முழுப் பதிப்புரிமையுடையது / All Rights Reserved

ශ්‍රී ලංකා විභාග දෙපාර්තමේන්තුව ශ්‍රී ලංකා විභාග දෙපාර්තමේන්තුව ශ්‍රී ලංකා විභාග දෙපාර්තමේන්තුව ශ්‍රී ලංකා විභාග දෙපාර්තමේන්තුව ශ්‍රී ලංකා විභාග දෙපාර්තමේන්තුව
 இலங்கைப் பரீட்சைத் திணைக்களம் இலங்கைப் பரීட்சைத் திணைக்களம் இலங்கைப் பரීட்சைத் திணைக்களம் இலங்கைப் பரීட்சைத் திணைக்களம் இலங்கைப் பரීட்சைத் திணைக்களம்
 Department of Examinations, Sri Lanka Department of Examinations, Sri Lanka Department of Examinations, Sri Lanka Department of Examinations, Sri Lanka Department of Examinations, Sri Lanka

අධ්‍යයන පොදු සහතික පත්‍ර (උසස් පෙළ) විභාග, 2018 අගෝස්තු
 கல்விப் பொதுத் தராதரப் பத்திர (உயர் தர)ப் பரீட்சை, 2018 ஆகஸ்ட்
 General Certificate of Education (Adv. Level) Examination, August 2018

භෞතික විද්‍යාව	II
பௌதிகவியல்	II
Physics	II

PART B – Essay

01 E II

Answer four questions only.
 (Acceleration due to gravity $g = 10 \text{ N kg}^{-1}$)

5. (a) Bernoulli's equation for a fluid flow can be written as $P + \frac{1}{2}dv^2 + hdg = \text{constant}$, where all symbols have their usual meaning. Show that the term $\frac{1}{2}dv^2$ has the **unit** of energy per unit volume.
 (b) Sri Lanka has one of the most advanced ancient irrigation systems in the world. Such an irrigation system which supplies water for farmers and villagers consists of three major features as shown in figure (1).

- Feature 1 :** The tank or reservoir and the dam.
Feature 2 : The outgoing water canal from the tank which is exposed to **atmosphere**.
Feature 3 : The Bisokotuwa (also known as cistern sluice) is a rectangular shaped vertical tower chamber with walls made of stones or bricks (see figure (1)). When it is required to release water from the tank, the water is first allowed to enter the Bisokotuwa in which the speed of the water flow is drastically reduced. One reason for this reduction is the sudden increase in the cross-sectional area of the water flow within the Bisokotuwa. In addition, a substantial amount of energy of the water flow is also lost, within the Bisokotuwa, due to the collision of water with the stone walls of the Bisokotuwa.

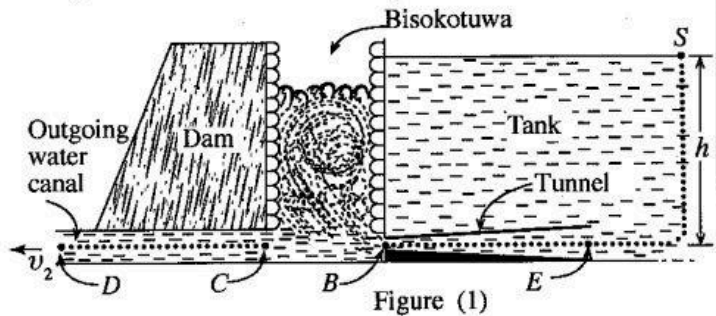

For your calculations, assume that the steady and streamline flow conditions can be applied along the dotted line paths shown in figures and the height of the water level in the tank remains unchanged.

- Consider an irrigation system which consists of **only** the features 1 and 2 as shown in figure (2).
 (i) If the height of the water level in the tank is h , derive an expression for the speed v_1 of the outgoing water at point Q in terms of h and g .
 (ii) If $h = 12.8 \text{ m}$, calculate the value of v_1 .
 (iii) Calculate the kinetic energy per unit volume carried by the water at point Q. The density of water is 1000 kg m^{-3} .

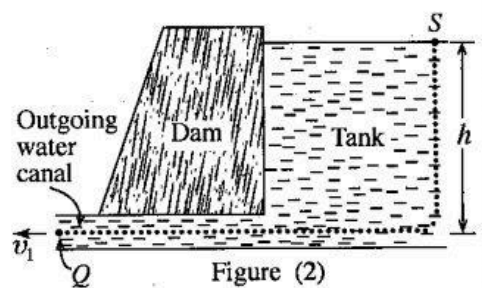

- (c) To control the destructive power of the outgoing water, ancient engineers incorporated the feature 3, the Bisokotuwa to the tank as shown in figure (1).
 (i) The water enters from the tank to the Bisokotuwa through a tunnel as shown in figure (1). Assume that the tunnel is tapered, and areas of cross-sections of the tunnel at the inlet and outlet are A and $0.6A$ respectively. Calculate the speed v_B of the water flow at the point B in the tunnel. Take the speed of the water flow at the inlet E of the tunnel as 12 m s^{-1} .
 (ii) Calculate the pressure P_B of the water flow at the point B in the tunnel. The atmospheric pressure is $1 \times 10^5 \text{ Nm}^{-2}$.
 (iii) Consider a point C in the outgoing water canal where the pressure and the speed of the water flow are at the values of 75% of P_B and 65% of v_B respectively.
 (1) **Write down** the value of the pressure of water flow P_C at the point C.
 (2) **Write down** the value of the speed of water flow v_C at the point C.
 (iv) Calculate the speed v_2 of the outgoing water at point D shown in figure (1).
 (v) Calculate the **percentage loss**, in kinetic energy per unit volume carried by the water at point D shown in figure (1) with respect to the value calculated in (b)(iii) above.
 (vi) Explain briefly, how ancient engineers managed to control the destructive power of the outgoing water flow by adding the Bisokotuwa to the irrigation system.

6. Read the following passage and answer the questions.

Ocean waves are generally caused by wind and gravity. Wind-driven waves in the ocean as well as tsunami waves and tidal waves are some examples of gravity waves. When wind blows across the surface of the ocean, water surface of the ocean is continuously disturbed by the wind. Under this situation the force of gravity tries to restore the equilibrium at the interface between water and air. As a result, ocean waves are created. Ocean waves can be categorized into two main types, namely deep-water waves and shallow-water waves. The terms, shallow-water waves and deep-water waves have nothing to do with the true depth of the ocean. The waves present in the ocean where the depth (h) of the ocean is greater than half the wavelength (λ), of the wave are called deep-water waves. When the depth (h) in the ocean is less than half the wavelength (λ), of the wave they are called shallow-water waves. The wavelengths of deep-water waves are in the range of 1 m–1 km whereas the wavelengths of shallow-water waves are in the range of 10 km–500 km in the ocean. The value of the speed of propagation v of shallow-water waves in the ocean of depth h is given by $v = \sqrt{gh}$. The average depth of the ocean is about 4 km.

Major tsunamis are caused by large-scale disturbances in the ocean, such as underwater earthquakes, volcanic eruptions occurring on or below the ocean floor, and impact of a large meteorite with ocean. A tsunami is a series of ocean waves with very long wavelengths, ranging from 10 km–500 km in the deep ocean. Even though the shape of a tsunami wave can be approximated to a sinusoidal wave in the deep ocean far away from the shore, it gradually takes a complex form as it reaches the shallow water near the coast as shown in figure 1(a). Depending on whether the first part of the tsunami wave which reaches the shore is a crest or a trough, it may appear as a rapidly rising or falling tide. In some situations, the front of the waveform can take a very complex shape near the shoreline as shown in figure 1(b), and it may appear as a rapidly receding of the shoreline followed by an incoming huge wave height grown up to several metres. The rate of transfer of tsunami wave energy through the ocean surface, which depends on both its wave speed and wave height, remains nearly constant. In general, the value of the height H_s of the tsunami wave as it enters shallow water is given by

$H_s = H_d \left(\frac{h_d}{h_s} \right)^{\frac{1}{4}}$, where H_d is wave height in deep water, and h_s and h_d are depths of the shallow and deep water respectively.

When tsunami waves propagate across the ocean the wave crests can undergo refraction. It is caused by segments of the wave moving at different speeds as the water depth along the wave crest varies. In addition, due to uneven variation of the ocean floor near the coast and obstacles such as small islands, reefs, etc., on the tsunami path, these waves undergo interference and diffraction. The distribution of tsunami wave heights was estimated by a group of scientists along the coastline of Sri Lanka after the devastating tsunami that had occurred in December 26, 2004. The length of the lines in figure (2) shows the heights of the tsunami wave crests along the coastline. Superposition of waves from the primary source and reflected and diffracted waves from obstacles was responsible for the erratic pattern of the wave heights and the varying damage along the coastline.

- Explain briefly how the ocean waves are created by wind and gravity.
- What is the difference between deep-water waves and shallow-water waves exist in the ocean?
- What are the **three** causes of tsunami wave formation mentioned in the passage?
- Identify the type of the tsunami waves possible in ocean (deep-water waves or shallow-water waves), and estimate the speed of tsunami waves in m s^{-1} in the ocean having an average depth of 4 km.
- The height of tsunami wave rapidly increases as it approaches shallow water near the coast. Explain qualitatively why this happens.
- Calculate the height of the tsunami wave in the ocean at a place where the water depth is 6250 m. Take the height of the wave at a water depth of 10 m as 5 m. Considering the wavelength of tsunami, explain why it is difficult to detect tsunami waves in the deep ocean.

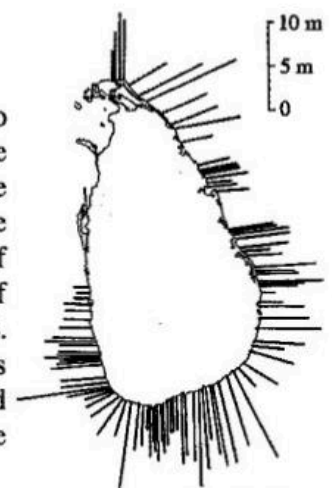
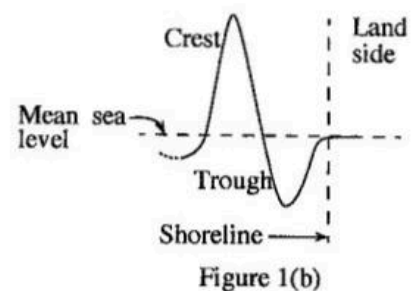
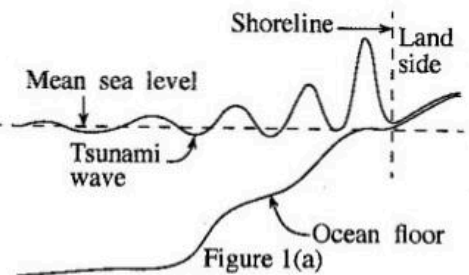
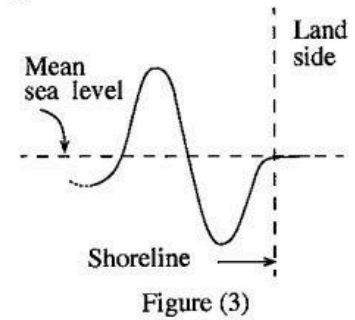

Figure (2)

- (g) Assuming that a tsunami wave takes the shape shown in figure (1)(b) at the shoreline, explain briefly why the shoreline recedes from the land just before the arrival of the huge mass of water.
- (h) If the tsunami waveform mentioned in question (g) above can be approximated to part of a sinusoidal wave as shown in figure (3), calculate the time duration in **minutes** between the instant that the shoreline starts receding into the ocean and the arrival of the water mass at the former shoreline. For the part of sinusoidal wave, take $v = 10 \text{ m s}^{-1}$ and $\lambda = 18 \text{ km}$.
- (i) Figure (2) shows some locations where the wave height is very high compared to their adjoining regions having very low wave heights. What phenomenon could be responsible for this? Explain your answer.
- (j) Briefly explain the reason why the tsunami waves in 2004 reached even the west coast of the island as shown in figure (2).



7. (a) Concrete is a hardened mixture of cement, sand, gravel and water. Reinforced concrete structures are structures composed of concrete and steel bars. All rigid bodies, such as steel and concrete are elastic to some extent. Concrete is strong under compression but **weak** under extension while steel is strong under both situations. As a combination, concrete mainly resists compression, and steel bars mainly sustain the tension.

Consider a plain concrete beam having rectangular cross-section, and **without** steel bars, kept on two supports, and subjected to a load W as shown in figure 1(a). Under this situation the bottom part of the beam will experience an extension while the top part will experience a compression as shown with dotted lines.

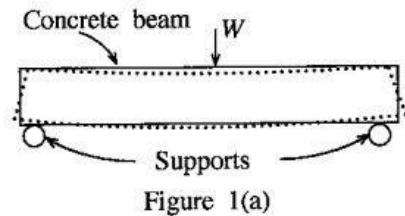

- (i) Which side of the plain concrete beam (top or bottom) is most vulnerable to crack under the load W ?
- (ii) To improve the situation shown in figure 1(a), steel bars are inserted closer to the bottom of the concrete beam at the production stage as shown in figure 1(b). Based on the information given at the beginning of the question, explain, how this improves the load bearing capacity and prevents cracking of the concrete beam.

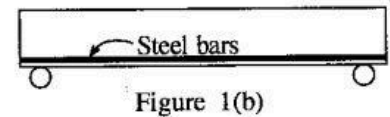

- (b) The tensile stress $\left(\frac{F}{A}\right)_S$ - strain $\left(\frac{\Delta l}{l}\right)_S$ relationship for mild steel (S) can be modelled, as shown in figure 2(a). Even though concrete is a brittle material, the tensile stress $\left(\frac{F}{A}\right)_C$ - strain $\left(\frac{\Delta l}{l}\right)_C$ relationship of the concrete (C) **under tensile force** can also be modelled as shown in figure 2(b). In reinforced concrete, steel bars are well bonded to concrete, thus they can jointly resist external loads together until concrete cracks.

When the curve reaches the point P shown in figure 2(b), the **concrete will crack**.

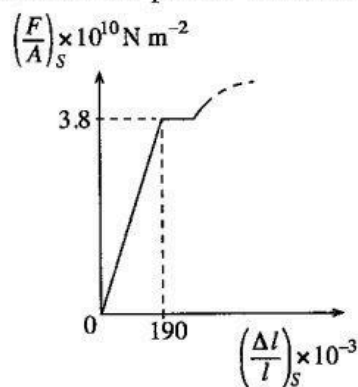

Figure 2(a)

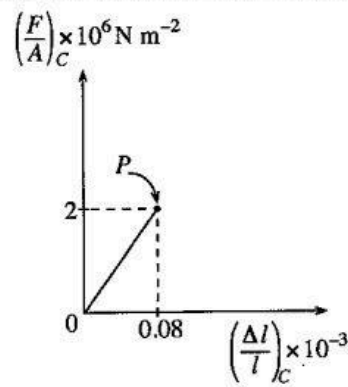

Figure 2(b)

Using the figures 2(a) and 2(b),

- (i) calculate Young's modulus of mild steel E_S .
- (ii) calculate Young's modulus of concrete E_C .

(c) Figure (3) shows a reinforced uniform concrete beam of length l kept on a rigid horizontal surface. The beam is reinforced with concrete and identical four uniform cylindrical mild steel bars each of length l . The tensile stress-strain relationships corresponding to the concrete and the steel used are given in figures 2(a) and 2(b) respectively. Assume that the beam is subjected to total tensile force of F_t applied uniformly throughout the area of cross-section of the beam, and mild steel bars and concrete produce **same extension Δl** under the tensile force.

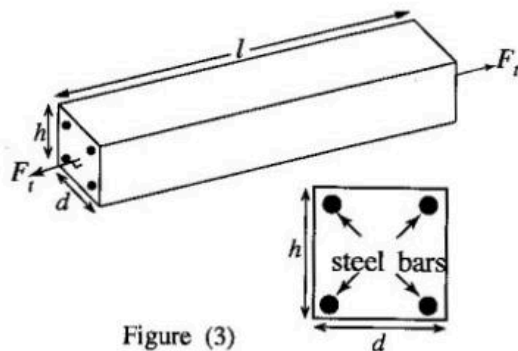

Figure (3)

cross-sectional view

- Write down an expression for the tensile force (F_C) on concrete in terms of E_C , area of cross-section of the concrete A_C , l and Δl .
- Write down an expression for the tensile force (F_S) on the four mild steel bars in terms of E_S , total area of cross-section of the four mild steel bars A_S , l and Δl .
- Prior to concrete cracking, if the total tensile force (F_t) is carried by both concrete and the steel, obtain an expression for the **total** tensile force F_t on the reinforced concrete beam.
- The area of cross-section A of the reinforced concrete beam is dh . See figure (3). For the beam, take $l = 2000$ mm, radius of a cylindrical mild steel bar $r = 6$ mm, $\Delta l = 0.1$ mm, $d = 150$ mm and $h = 250$ mm.
 - Physically under what condition the expression obtained in (c)(iii) above is valid? Use the data provided above for the reinforced concrete beam and show that the expression obtained in c(iii) is physically valid for the beam.
 - Calculate the value of F_t . (For your calculation, if $\frac{A_S}{A} \leq 3\%$ then take $A_C = dh$, otherwise take $A_C = dh - A_S$. Take π as 3.)
- Calculate the minimum tensile force which cracks the reinforced concrete beam.

8. A copper strip of width d and thickness t carries a current I from top to bottom as shown in figure 1(a). The strip is kept in a uniform magnetic field of flux density B directed perpendicular and into the plane of the strip. Cross-sectional view of the same arrangement is also shown in figure 1(b). The charge carriers are electrons and they drift with drift speed v_d .

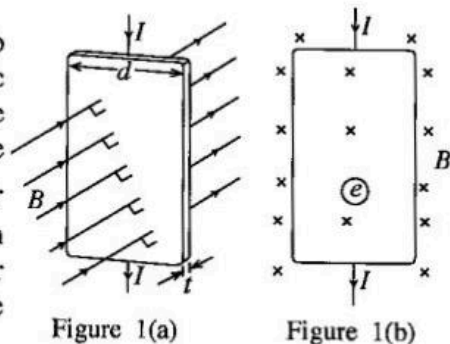

Figure 1(a)

Figure 1(b)

- What is the direction of the magnetic force acting on the electron \ominus shown in figure 1(b)? Copy the figure 1(b) to your answer script and clearly draw an arrow on the electron to indicate the direction of this force.
 - Now if you replace the copper strip shown in figure 1(b) with another strip having positively charged carriers, what is the direction of the magnetic force acting on a positively charged carrier?
- As time goes on, in the copper strip described in (a)(i) above, there would be a new equilibrium situation with regard to the **charges residing**. Copy figure (2) to your answer script and illustrate this new equilibrium situation using '+' to represent positive charges and '-' to represent negative charges.
 - Explain the reason to have the equilibrium condition as mentioned in (b)(i).
 - Briefly describe how you would use this effect to verify that holes in a p-type semiconductor are positively charged carriers.
- Derive an expression for the Hall voltage V_H in terms of v_d , B and d .
 - The current I flowing through a conductor, such as copper, can be written as $I = neAv_d$, where all symbols have their usual meaning.
 - Derive the equation $I = neAv_d$.
 - Obtain an expression for V_H for the copper strip in terms of n , e , t , I and B .
 - Consider a copper strip of thickness 1×10^{-3} m in a uniform magnetic field of 0.5 T. If $I = 48$ A and $V_H = 1.5 \times 10^{-6}$ V, calculate the number of charge carriers per unit volume in copper. Take $e = 1.6 \times 10^{-19}$ C.

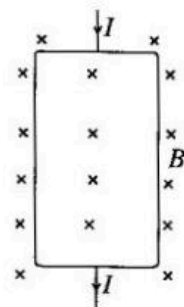

Figure (2)

- (d) Cardiologists monitor the flow speed of blood through an artery using an electromagnetic flow meters. A schematic diagram of the relevant parts of such a flow meter is shown in figure (3).

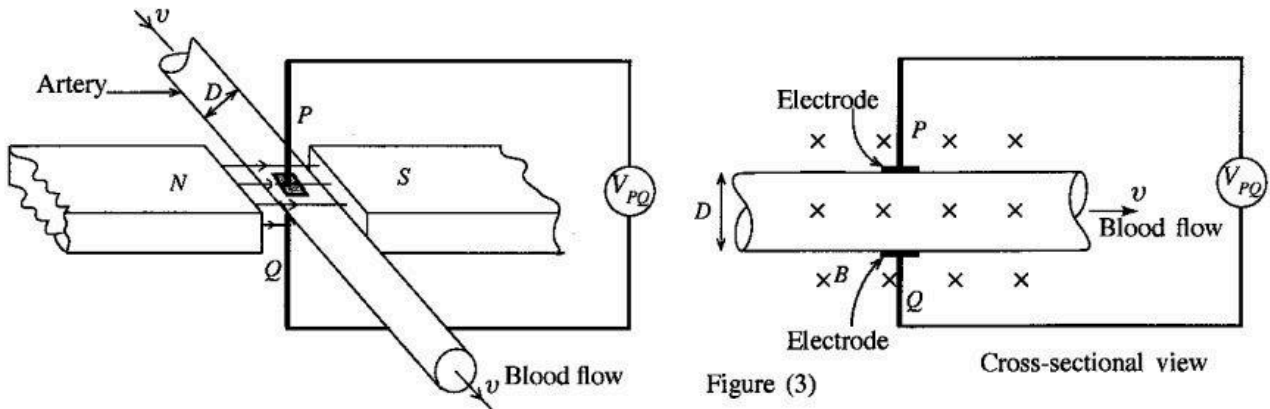

Figure (3)

Cross-sectional view

Blood plasma has a high concentration of Na^+ and Cl^- ions moving through the artery with the blood at the same speed v and same direction as the blood flow. Assume that the ions in the blood behave as charge carriers.

- When the blood flows through the artery shown in figure (3), what is the polarity of the electrode P ? Give the reason for your answer.
- If the flux density of the uniform magnetic field applied to the system is B and the diameter of the artery is D , write down an expression for the magnitude of the voltage V_{PQ} across the two electrodes P and Q in terms of v , B and D .
- If $V_{PQ} = 160 \mu\text{V}$, $D = 5 \text{ mm}$ and $B = 2 \times 10^3 \text{ gauss}$ ($1 \text{ gauss} = 10^{-4} \text{ T}$), calculate the value of speed v of the blood through the artery.

9. Answer either part (A) or part (B) only.

- (A) In the circuit shown in figure (1), 5 V cell has a negligible internal resistance. Z is a resistor.

- Once the switch S is closed calculate the power dissipation in the resistor Z when its value is $1 \text{ k}\Omega$.
- The switch is now closed and opened once to produce the rectangular voltage pulse $ABCD$ shown in figure (2).

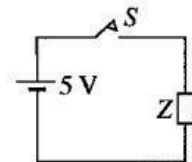

Figure (1)

Amplitude and the width of the voltage pulse are 5 V and 10 ms respectively. Once the pulse is produced it travels through the circuit with a speed of $2 \times 10^6 \text{ m s}^{-1}$. Assume that the rectangular shape of the pulse remains unchanged when it passes through the circuit.

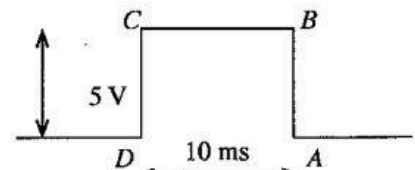

Figure (2)

- How long does the edge AB of the voltage pulse take to travel across the length of the resistor Z of 2 cm long?
 - Approximately how long does the full voltage of 5 V appear across the entire length of the resistor Z ?
 - Assuming that the resistor has a value of $1 \text{ k}\Omega$, calculate the energy dissipated in the resistor Z by the voltage pulse.
- (c) The switch S is now closed and opened regularly to produce the rectangular voltage waveform shown in figure (3).

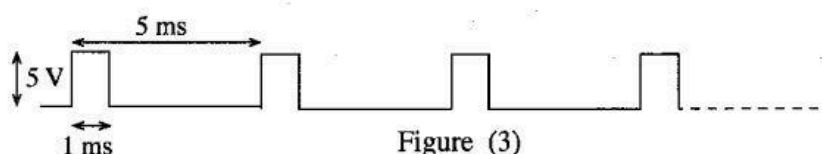

Figure (3)

As shown in figure (3), width of a pulse is 1 ms and the period of the voltage waveform is 5 ms . Under this situation, calculate the power dissipated in the resistor Z when its value is $1 \text{ k}\Omega$.

- (d) A rectangular current pulse of amplitude I_0 and width T_0 generated by a pulsating current source Y enters two resistive wires of lengths l_1 and l_2 as shown in figure (4).

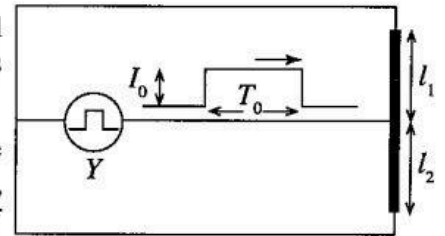

Figure (4)

- Assume that all the other connecting wires in the circuit have negligible resistance. The two resistive wires of lengths l_1 and l_2 , each having area of cross-section A , are made of a material of resistivity ρ .
- If R_1 and R_2 are the resistances of the wires of lengths l_1 and l_2 , respectively, write down expressions for R_1 and R_2 .
 - Derive expressions for the amplitudes I_1 and I_2 of current pulses through the wires of length l_1 and l_2 respectively in terms of I_0 , l_1 and l_2 .

- (e) A gaseous X-ray detector consists of a resistive anode wire PQ of length L surrounded by a suitable gas as shown in figure (5). Suppose an X-ray photon is absorbed by the gas producing a narrow electron pulse in the gas close to the point S of the anode wire as shown in figure (5). The anode wire has the capability of extracting this electron pulse from the gas and forming an electron current pulse at the point S of the anode wire PQ . Subsequently, the electron current pulse gets divided into two and move through the wire in either direction with speed v .

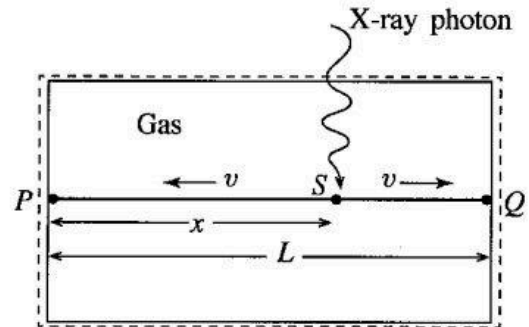

Figure (5)

If Δt is the **difference** in the arrival times of the two electron current pulses to reach the ends P and Q of the anode wire, derive an expression for the distance x from the point P to the point S where the X-ray photon is absorbed, in terms of Δt , v and L .

- (B)(a) The circuit shown in figure (1) is constructed using a silicon transistor of current gain 100. Assume that 0.7 V is needed to forward bias the base-emitter junction of the transistor.

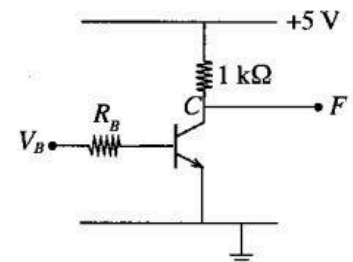

Figure (1)

- Calculate the maximum current possible through the collector resistor.
- Calculate the maximum value for R_B which ensures the condition stated in (i) above, for $V_B = 5$ V.
- If the transistor in the above circuit has been replaced later by a similar transistor but having a current gain of 50, keeping R_B at the value calculated in (ii) above.

- Calculate the voltage at the output F for $V_B = 5$ V.
- What is the new mode of operation of the transistor?

- (b) The digital circuit whose block diagram is shown in figure (2) operates as follows.

Each of the inputs A and B accepts binary 1 or 0. F_1 , F_2 and F_3 are outputs, where

$$F_1 = 1 \text{ only when } A < B, \text{ otherwise } F_1 = 0$$

$$F_2 = 1 \text{ only when } A = B, \text{ otherwise } F_2 = 0$$

$$F_3 = 1 \text{ only when } A > B, \text{ otherwise } F_3 = 0$$

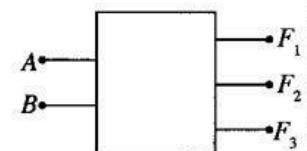

Figure (2)

- Prepare a truth table with A and B as inputs and F_1 , F_2 and F_3 as outputs.
- Write down Boolean expressions for F_1 , F_2 and F_3 .
- Draw a logic circuit which operates according to the conditions given above, using logic gates.

10. Answer either part (A) or part (B) only.

(A) Frying is a food processing technique which involves the use of hot oil as heating medium to prepare food. If the frying is done using a large quantity of oil with respect to the quantity of food material to be fried, then it is called deep frying. If it is done with a relatively smaller quantity of oil it is called stir frying. Generally deep frying takes place in the temperature range of 190°C – 140°C and the stir frying in the temperature range of 115°C – 100°C . Deep frying is expensive, as a large quantity of oil has to be replaced regularly, however, in most of the cases deep frying yields tastier food.

Results of an investigation conducted by a student in an attempt to achieve higher temperatures by using a small quantity of oil is given below. To increase the heat capacity of the system and thereby to achieve higher temperatures, he has used small reusable solid porcelain spheres mixed with a relatively small quantity of oil.

(a) As the first step, the student poured 0.2 kg of oil into a suitable pot having outer walls covered with an insulating material, and heated upto 200°C using a small immersion heater. The heater was then removed and 0.2 kg of dry food material was added instantly and mixed with the oil. If the specific heat capacities of the oil and the food material are $1650\text{ J kg}^{-1}\text{ }^{\circ}\text{C}^{-1}$ and $1600\text{ J kg}^{-1}\text{ }^{\circ}\text{C}^{-1}$ respectively, and the initial temperature of food material is 30°C , calculate the final temperature of the mixture. Assume that the heat capacity of the empty pot is negligible compared with that of oil, and the heat loss to surrounding is also negligible.

(b) Student then emptied the pot and added the same amount (0.2 kg) of fresh oil as in (a) above and also a certain amount of small solid uniform porcelain spheres. Assume that the added spheres get packed, in the regular manner (regular packing) as shown in figure (1). The spheres were added to the pot in such a way that the space of the voids created by the spheres when get packed occupies half the volume of oil in the pot (see figure (1)).

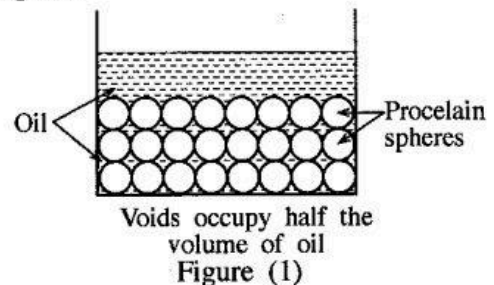

(i) As the spheres are packed in the regular manner, considering the unit cubes occupied by spheres as shown in figure (2), show that the **total volume of spheres** is equal to the volume of oil containing in the voids. (Take $\pi = 3$.)

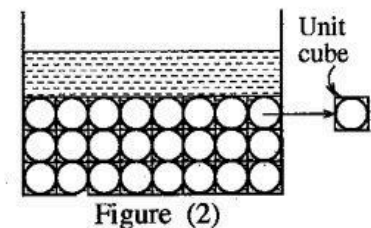

(ii) If the densities of the oil and porcelain are 900 kg m^{-3} and 2500 kg m^{-3} respectively, calculate the mass of the porcelain spheres.

(iii) The student then heated the pot containing oil together with the porcelain spheres upto 200°C , and again added and mixed the same amount (0.2 kg) of the same food material at 30°C , as in (a) above. If the specific heat capacity of porcelain is $1000\text{ J kg}^{-1}\text{ }^{\circ}\text{C}^{-1}$, calculate the final temperature of the mixture. Neglect the heat capacity of the empty pot and the heat loss to surrounding.

(c) What is the advantage if smaller porcelain spheres than those used in the above investigation are used?

(B)(a) The diagram given in figure (1) shows the essential parts of a setup necessary to carry out the photoelectric effect experiment.

(i) The part marked as *D* is a voltage supply. What are the **two** main features, *D* should have in order to obtain photoelectric current (*I*) – potential difference (*V*) characteristic?

(ii) Name the parts labelled as *A* and *B*.

(iii) Two monochromatic light beams, green [wavelength λ_g] and red [wavelength $\lambda_r (> \lambda_g)$] colours with **same** intensities measured in W m^{-2} , are allowed to incident on *A*, one beam at a time. The frequencies of the light beams are higher than the threshold frequency of the material made of *A*.

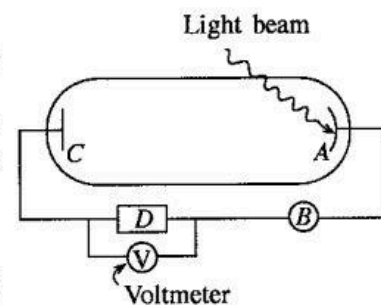

Figure (1)

(1) Draw a rough sketch to indicate the variation of *I* with *V*, for both green and red colours in the **same** graph. The curves for green and red colours should be clearly labelled as *G* and *R* respectively. Assume that same percentage of incident green and red colour photons emit photoelectrons.

(2) If the difference between the stopping potentials is ΔV , and the difference between the frequencies is Δf for green and red colours, obtain an expression for the ratio $\frac{\Delta f}{\Delta V}$, in terms of Planck's constant *h* and magnitude of the electronic charge *e* using the Einstein's photoelectric effect equation.

- (b) A certain photoelectric smoke alarm system mainly consists of a T-shaped chamber fitted with a monochromatic light emitting diode (LED), a photocathode and an electronic alarm as shown in figure 2(a).

Under the normal smoke-free condition, the photons of the LED light beam travel through the chamber and move away without striking the photocathode as shown in figure 2(a). When smoke enters the chamber, some of the photons collide with the smoke particles and move in different directions without change in their wavelength as shown in figure 2(b). The number of photons thus collides is proportional to the number of smoke particles present in the chamber. Out of the collided photons, a certain number is incident on the photocathode and generates a small photoelectric current. When a sufficient number of photons is incident on the photocathode it generates an adequate current to activate the electronic alarm.

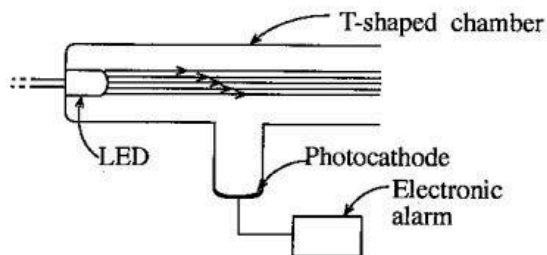

Figure 2(a)

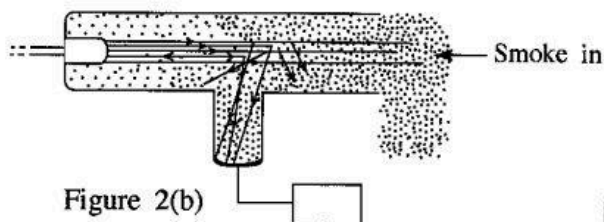

Figure 2(b)

- (i) If the wavelength of the photons emitted by the LED is 825 nm, calculate the energy of a photon in eV.
Take $h = 6.6 \times 10^{-34}$ Js, speed of light in vacuum $c = 3 \times 10^8$ ms⁻¹ and $1 \text{ eV} = 1.6 \times 10^{-19}$ J.
- (ii) Two photocathodes X and Y, made of materials with work functions 1.4 eV and 1.6 eV respectively, are available to you. Which photocathode (X or Y) is suitable to construct a smoke alarm system with the LED mentioned in (b)(i) above? Justify your answer.
- (iii) Power of the LED is 10 mW. If only 3% of energy goes into produce light of wavelength of 825 nm, calculate the number of photons emitted by the LED per second.
- (iv) Photocathode should receive at least 20% of the emitted photons per second from the LED to activate the alarm. Calculate the minimum number of photons per second that should be incident on the photocathode to activate the alarm.
- (v) When photons are incident on the photocathode, only a part of the incident photons contributes to the emission of photoelectrons. Assuming that only 10% of incident photons emits photoelectrons, calculate the minimum photoelectric current that should be generated by the photocathode to activate the alarm. Take $e = 1.6 \times 10^{-19}$ C.

* * *